

KOMATSU

PC7000-6 Loading Shovel PC7000-6 Backhoe

ENGINE POWER

2 x 1250 kW / 1675 HP @ 1800 rpm

OPERATING WEIGHT

676 – 694 ton / 1,490,600 – 1,530,300 lb

SHOVEL CAPACITY

36 m³ 47 yd³ SAE 2:1 heaped

BACKHOE CAPACITY

36 m³ 47 yd³ SAE 1:1 heaped

PC
7000



HYDRAULIC EXCAVATOR

WALK-AROUND

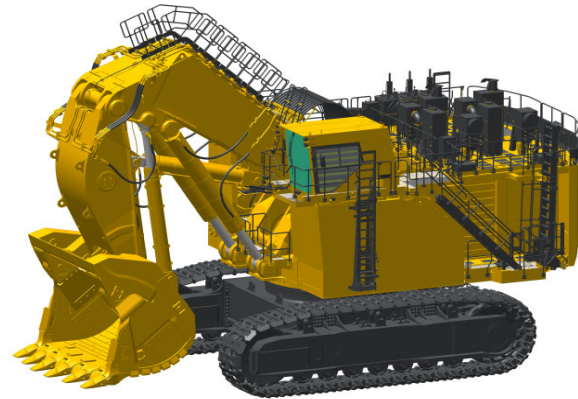
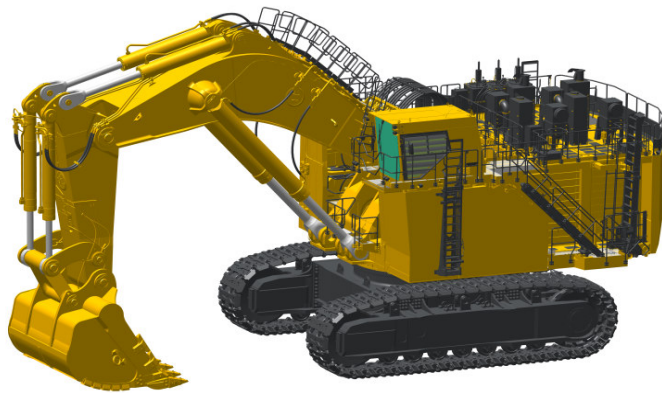

Quality in Manufacturing

Commitment to „Quality and Reliability“

- Quality management ISO 9001
- Environmental management ISO 14001
- Occupational health and safety management system BS OHSAS 18001:2007
- High consistent quality through continuous investment in personnel, design and manufacturing systems and processes

Powerful Diesel Engine

Two Komatsu SSDA16V159E-2 Tier 2 engines

- Rated (each) 1250 kW at 1800 rpm
- Electronic engine management
- Low engine emission levels Tier 2 certificated
- Time saving Engine Oil Management System; Centinel, Engine Reserve Oil Supply and Eliminator Oil Filter System

Electric Drive, optional available

Two squirrel cage induction motors

- Output: 2 x 1200 kW
- Frequencies: 50 Hz or 60 Hz
- Rated voltage: 6,0 kV up to 7,2 kV

Reliability and Durability

Long life and low operating cost by design

- Robust structural design developed from field experience and finite element analysis

Undercarriage

- Large diameter rollers, idlers and sprockets
- Large surface area and extensive precision hardening of all engaging components reduce track wear
- Hardened track link pin bores

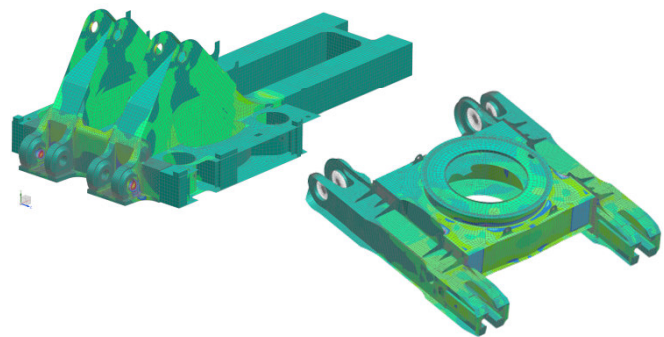

Access and Egress

- 45° primary access and egress stairways
- 45° access swing stairway
- 3 emergency egresses
 - cab and machinery house (two pieces flip down solid anti slip steel ladder)
 - machinery house escape
- Illuminated accesses and egresses

Productivity

Designed for more tons per hour

- Powerful digging forces
- Ease of bucket filling
- Proven attachment design
- All cylinders mounted in the shadow of the attachment for protection
- Various buckets and wear packages to suit all material densities and properties

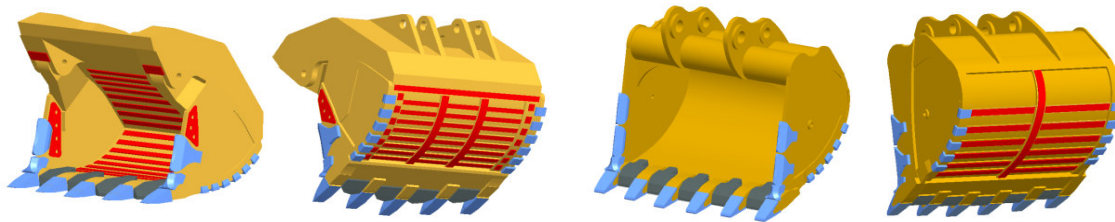

MATCHES

240 to 290 U.S. ton TRUCKS

OPERATING WEIGHT

Shovel 676-686 ton
1,490,600-1,512,600 lb

Backhoe 684-694 ton
1,508,200-1,530,300 lb

BUCKET CAPACITY

Shovel 36 m³ 47 yd³
Backhoe 36 m³ 47 yd³

Advanced Hydraulics

Extended reliability and precise control

- Comprehensive monitored filtration
- Simple open circuit hydraulic system with high efficiency swing out oil coolers

Large Comfortable Cab

Comfortable for the whole day

- Komatsu low noise cab on multiple viscous mounts for reduced noise and vibration
- Large volume cab with full height front window
- Comprehensive climate control with pressurised filtered air ventilation and air conditioning
- High specification multi-adjustable air suspension seat plus trainer seat
- Well elevated operator position giving good all round view
- Large wash wiper covers windshield area for excellent visibility

Easy and Safe Maintenance

Simple, common-sense design provides easy access to all major components

- Generous access to all major service points from machinery house floor level
- Enclosed, walk-in machinery house with partition wall separating engine from pump area
- Automatic central lubrication
- KOMTRAX Plus electronic monitoring system providing real time information about the operating status of the machine
- Ground-level access to hydraulically powered swing down service arm with Wiggins connections
- Acknowledges EMESRT design philosophies

SPECIFICATIONS



DIESEL DRIVE

Tier 2 engine:
 Model 2 x Komatsu SSDA16V159E-2
 Type 4-cycle, water-cooled, direct injection
 Aspiration Turbocharged and aftercooled
 Number of cylinders 16
 Rated power 2 x 1250 kW 1675 HP @ 1800 rpm (SAE 1995/J1349)
 Governor All-speed, electronic
 The integrated engine oil and filter system combining the oil stabilising systems, Reserve and Centinel, with Eliminator oil filter extends the oil change interval up to 4.000 hours based on oil analysis. The high capacity Mesabi engine radiators are cooled by a hydraulically driven fan for superior cooling efficiency.



ELECTRIC SYSTEM (Diesel Version)

System 24 V
 Batteries (series/parallel) 8 x 12 V
 Alternator 2 x 140 A
 Standard working lights 16 LED lights
 Standard service lights throughout the platform
 incl. emergency egresses and stairways



UNDERCARRIAGE

Undercarriage consists of one centre carbody and two track frames, each side attached by high torque bolts
 Centre frame H-type
 Track frame Steel box-section



CRAWLER ASSEMBLY

Track adjustment Automatic hydraulic type
 Number of track shoes 48 each side
 Number of top rollers 3 each side
 Number of bottom rollers 7 each side



TRAVEL AND BRAKE SYSTEMS

Travel control 2 foot pedals
 Gradeability Up to 50 %
 Travel speed (maximum) 2,5 km/h 1.55 mph
 Service brake Hydraulic brake
 Parking brake Wet, multiple-disk



SWING SYSTEM

Hydraulic motors and drives 3
 Swing brake, service Hydraulic brake
 Swing brake, parking Wet, multiple-disc
 Swing ring teeth External
 Swing speed (optimized to 90° swing) 3,1 rpm



ELECTRIC DRIVE

Type 2 x Squirrel cage induction motor
 Power Output 2 x 1200 kW
 Voltage 6.000 – 7.200 V*
 Amperage (approximate) 2 x 128 A - 2 x 107 A
 Frequency standard 60 Hz @ 1800 rpm
 Frequency option 50 Hz @ 1500 rpm
 * Other voltages available on request



ELECTRIC SYSTEM (Electric Version)

System 24 V
 Batteries (series/parallel) 4 x 12 V
 Battery charger 3 x 100 A
 Standard working lights 16 LED lights
 Standard service lights throughout the platform
 incl. emergency egresses and stairways



HYDRAULIC SYSTEM

The power train consists of two main drives. Each of the two gearboxes drives three identical pumps which draw hydraulic oil from an unpressurised hydraulic tank. Open circuit hydraulics provide maximum cooling and filtering efficiency.
 Rated flow (total output) 6.210 ltr/min / 1,640 gpm
 Relief valve setting 310 bar / 4,495 psi
 Swing flow rate 1.035 ltr/min / 273 gpm
 High pressure in line filters 200 microns
 one per pump located at the valve blocks
 Full flow return line filters 10 microns
 at head of hydraulic tank
 Case drain/by-pass return line filters 3 microns
 The four-circuit system features a load-limiting governor with oil delivery summation to the working circuits and incorporates pressure cut-off control. Hydropilot prioritises hydraulic flow giving smooth hydraulic response, simple hydraulic system layout, and a reduced number of components. The hydraulic system includes large swing-out vertical air-to-oil hydraulic coolers with temperature-regulated hydraulically driven fans.



AUTOMATIC CENTRALISED LUBRICATION

Three hydraulically powered Lincoln single line automatic lubrication systems are provided as standard, complete with time and volume variable controls. The two central lubrication circuits and open gear grease circuit are supplied by identical pump assemblies from refillable containers which have a capacity of 1x 600 and 1x 300 litres (total 238 gal). Replenishment of the containers is through the Wiggins connections on the service arm.



SERVICE CAPACITIES

Hydraulic oil tank 4.750 ltr / 1,255 U.S. gal
 Hydraulic system 9.500 ltr / 2,510 U.S. gal
 Fuel 13.033 ltr / 3,443 U.S. gal
 Engine coolant 2 x 440 ltr / 116 U.S. gal
 Engine oil 2 x 236 ltr / 62 U.S. gal
 Reserve engine oil make up tank 2 x 665 ltr / 176 U.S. gal

OPERATOR CAB

The large and comfortable cab is mounted on 18 viscous damping pads and sound insulated. The cab has automatic climate control and is pressurised. The operator's seat is air suspended, electrically heated and has a lap seat belt and offers multiple adjustments. The trainer seat is also equipped with a seat belt. Low-effort joystick controls are electro-hydraulic with foot controls for front shovel clam, crawler and swing brake. Full instrumentation, KOMTRAX Plus and an AM/FM radio with MP3 ready CD player with AUX in is fitted. The windshield wash wiper has two speeds and intermittent operation. Amenities include a refrigerator and storage cabinets. Powered and heated mirrors are adjusted from inside the cab. External metal sun blinds on the cab side window and internal roller blinds on all windows are standard. The left hand window is an emergency exit. All windows are tinted parsol green. The front window is a 19mm thick impact resistant window. A walkway is mounted in front of cabin.

Major cab engineering standards are:

- ISO 3449 Falling Objects Protection Structure (FOPS)
- ISO 6396 Noise in operator's cab is max. 75 dB(A)
- ISO 2631-1 Whole body vibration and shock below 0,5 m/s²
- ISO 5349-1 Hand-lever vibration lower than 2,5 m/s²
- ISO 10263-4 Heating and air conditioning second heater or air conditioner as option

KOMTRAX PLUS HEALTH MONITORING SYSTEM

KOMTRAX Plus is designed for Komatsu mining equipment to provide real time information about the operating status of the machine via a coloured display. The integrated digital storage provides a full event history and trend data, which can be downloaded by laptop. Optionally available are W-LAN or Orbcmm satellite transmission (check for availability in your territory).

OPERATING WEIGHTS (APPROXIMATE)

PC 7000 Backhoe:

Operating weight including 11.000 mm 36'1" boom, 5.100 mm 16'9" stick, 36 m³ (47 yd³) backhoe bucket, operator, lubricant, coolant, 1/3 fuel and standard equipment.

Shoe Width	Operating Weight	Ground Pressure
1500 mm 59"	684 t 1,508,200 lb	26 N/cm ² 37.7 psi
1900 mm 75"	694 t 1,530,300 lb	20,8 N/cm ² 30.2 psi

PC 7000 Front Shovel:

Operating weight including 8.000 mm 26'3" boom, 5.500 mm 18'1" stick, 36 m³ (47 yd³) shovel bucket, operator, lubricant, coolant, 1/3 fuel and standard equipment.

Shoe Width	Operating Weight	Ground Pressure
1500 mm 59"	676 t 1,490,600 lb	25,8 N/cm ² 37.4 psi
1900 mm 75"	686 t 1,512,600 lb	20,7 N/cm ² 30.1 psi

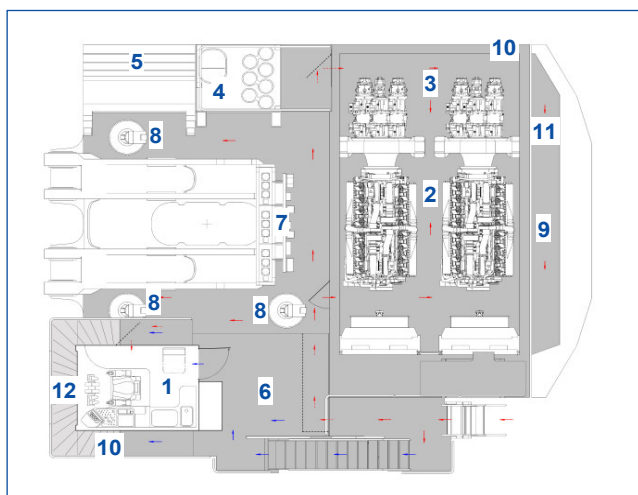

Diesel Drive

- | | |
|---------------------|--|
| 1 Cab | 7 Valve Blocks |
| 2 Diesel Engines | 8 Swing Motors |
| 3 Hydraulic Pumps | 9 Counterweight |
| 4 Hydraulik Tank | 10 Emergency swing ladder egress |
| 5 Hydraulic Coolers | 11 Emergency access out of machinery house |
| 6 Fuel Tank | 12 See-through Cat Walk |

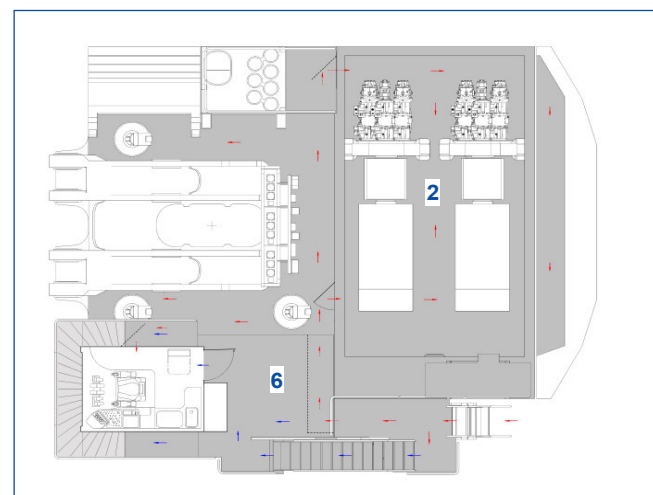

Variation for Electric Drive Version

- | |
|-------------------------|
| 2 Electric Motors |
| 6 High Voltage Electric |

Walkways ← Lower-Level
← Upper-Level

PC7000-6 HYDRAULIC EXCAVATOR

PRODUCTIVITY-FEATURES



BACKHOE ATTACHMENT

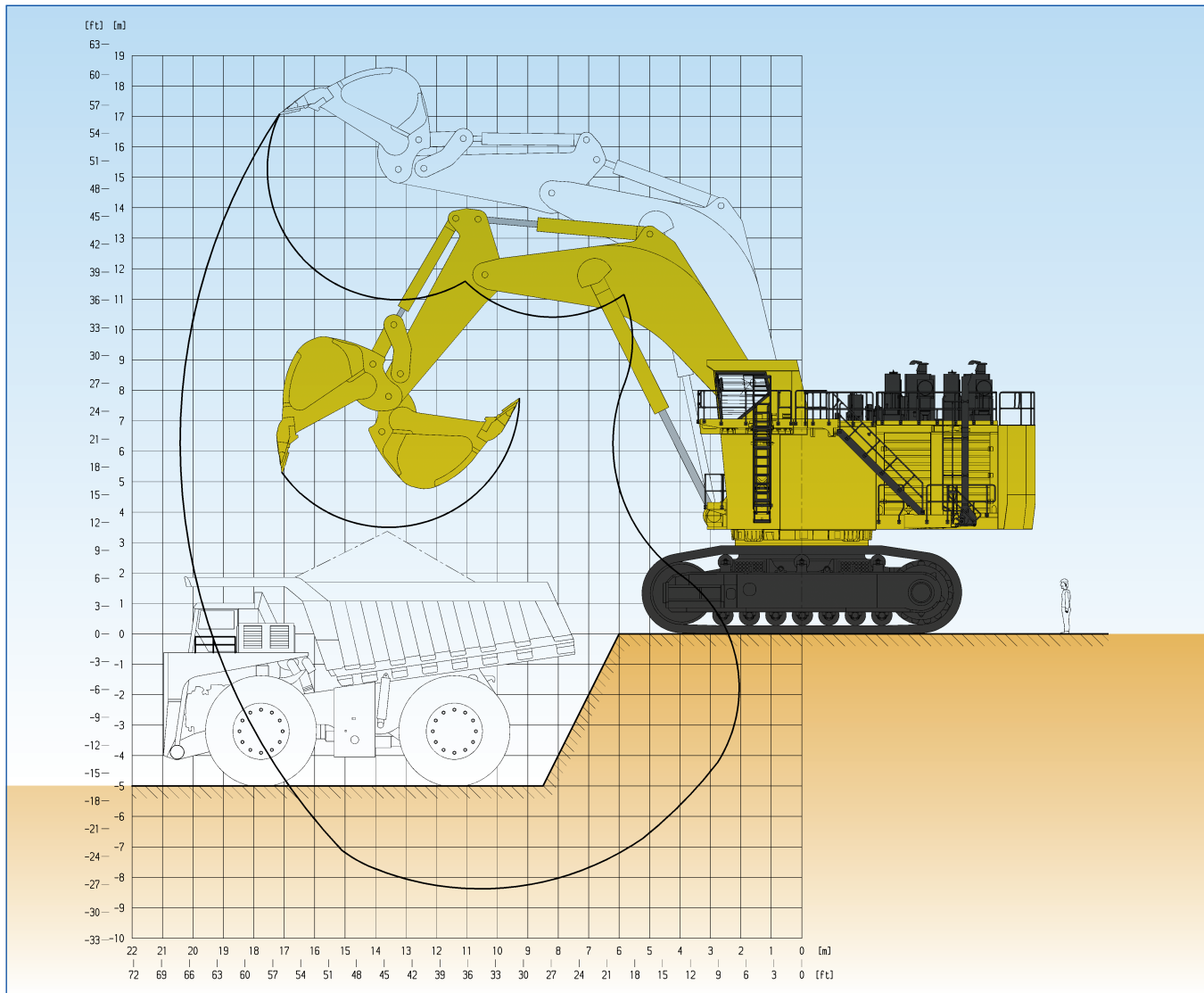

Boom length	11.000 mm	36'1"
Stick length	5.100 mm	16'1"
Break-out force (ISO)	1.741 kN	391,330 lb
Tear-out force (ISO)	1.513 kN	340,080 lb

Max. digging height	17.100 mm	56'1"
Max. dumping height	11.000 mm	36'1"
Max. digging depth	8.600 mm	28'3"
Max. digging reach	20.500 mm	67'3"
Max. digging reach at ground level	19.600 mm	64'4"

Bucket Capacity (Heaped 1:1) SAE		Width		Teeth	Wear Package acc. abrasiveness	GET System	Max. Material Density (Loose)	
cum	cuyd	mm	foot/inch	qty			t/cum	lb/cuyd
36,0	47.0	4.550	14'11"	6	heavy	Hensley XS 644 *	1,8	3,000
36,0	47.0	4.550	14'11"	6	standard	Hensley XS 644 *	1,8	3,000
36,0	47.0	4.550	14'11"	6	light	Hensley XS 644 *	1,8	3,000

Alternative buckets on request

*other systems on request



FRONT SHOVEL ATTACHMENT

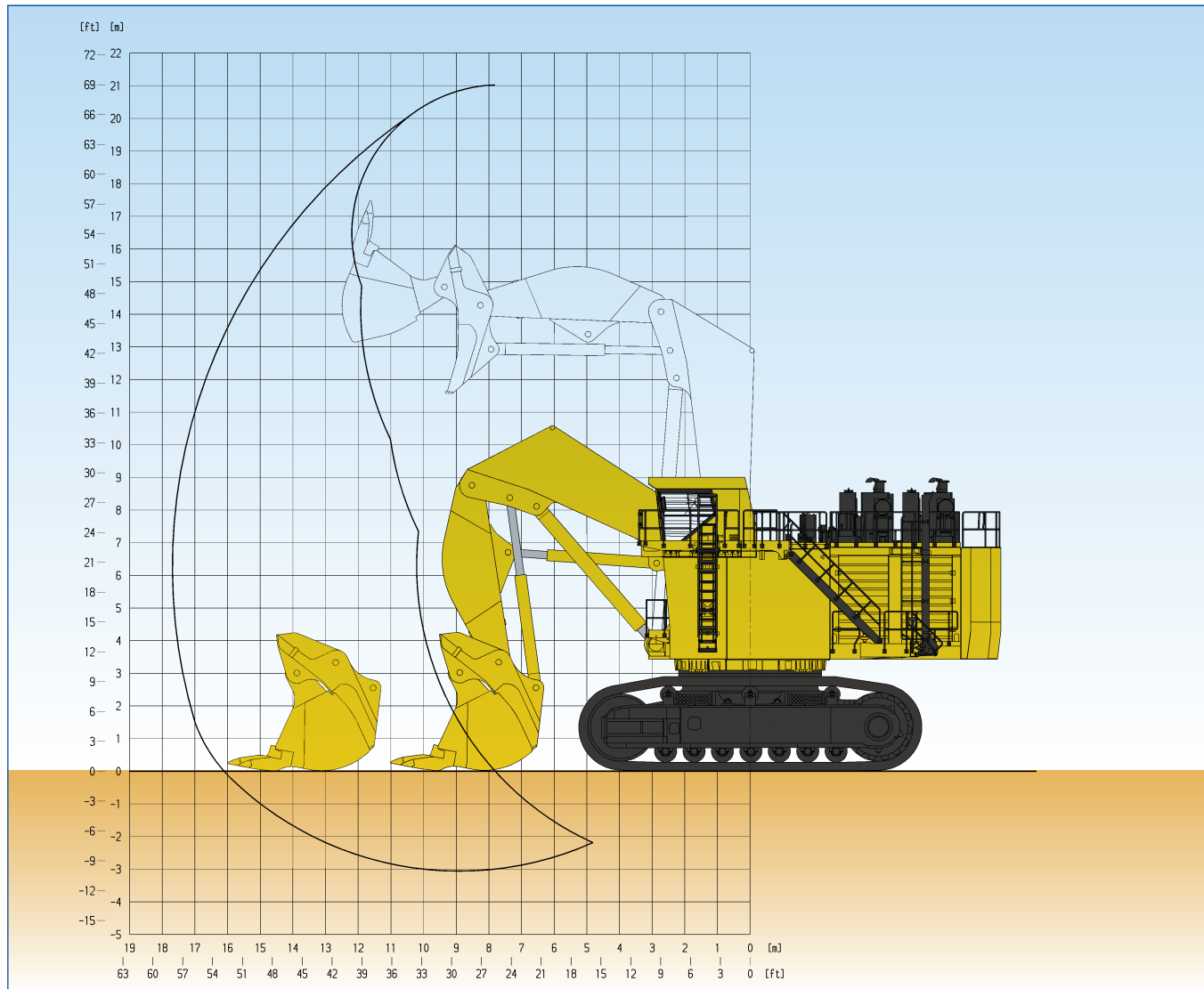

Boom length	8.000 mm	26'3"
Stick length	5.500 mm	18'1"
Break-out force (ISO)	2.086 kN	468,870 lb
Crowd force (ISO)	2.147 kN	482,580 lb

Max. cutting height	21.000 mm	68'11"
Max. dumping height	14.000 mm	45'11"
Max. digging depth	3.000 mm	9'10"
Max. digging reach	17.700 mm	58'1"
Level crowd at ground level	4.980 mm	16'4"
Bucket opening width	2.960 mm	9'9"

Bucket Capacity (Heaped 1:2) SAE		Width		Teeth	Wear Package acc. abrasiveness	GET System	Max. Material Density (Loose)	
cum	cuyd	mm	foot/inch	qty			t/cum	lb/cuyd
36,0	47.0	4.965	16'3"	6	heavy	Hensley XS 644 *	1,8	3,000
36,0	47.0	4.965	16'3"	6	standard	Hensley XS 644 *	1,8	3,000
38,0	49.7	4.965	16'3"	6	light	Hensley XS 644 *	1,8	3,000

Alternative buckets on request

*other systems on request



STANDARD EQUIPMENT

HYDRAULIC MINING SHOVEL

FRONT SHOVEL ATTACHMENT

- 8,0 m 26'3" boom
- 5,5 m 18'1" stick
- Set of cylinders
- 36 m³ (47 yd³) (SAE 2:1) shovel bucket incl. standard wear package with hammerless GET system

OR

BACKHOE ATTACHMENT

- 11,0 m 36'1" boom
- 5,1 m 16'9" stick
- Set of cylinders
- 36 m³ (47 yd³) (SAE 1:1) bucket incl. standard wear package with hammerless GET system

CRAWLER UNDERCARRIAGE

- Heavy-duty shovel type undercarriage
- Centre carbody
- 2 heavy box-type track frames
- 7 bottom rollers and 3 top rollers each side
- 1500 mm 59" cast steel track shoes
- Hydraulic track adjustment and parking brake
- Drive gear box protection

SUPERSTRUCTURE

- Main frame mounted over an externally toothed swing circle carries the drive module
- 2 x Komatsu SSDA16V159E-2 Tier 2 diesel engines
- Oil and fuel reservoirs
- Hydraulic components
- Counterweight

LIGHTING

- 16 LED high performance working lights
- Service lights throughout the platform incl. emergency egresses and stairways

OPERATOR CAB

- Enclosed steel cab mounted on viscous pads
- FOPS according ISO 3449
- Air-conditioning unit Süttrak
- Full suspension operator seat with belt
- Controls ergonomic
- KOMTRAX Plus (Monitoring System)
- Joysticks are electro-hydraulic
- 1 large parallel windshield wash wiper
- AM-FM radio with MP3 ready CD player & aux port
- Internal and external sun blinds
- All windows tinted parsol green
- Impact resistant front window (19mm)
- Walkway in front of cab

LUBRICATION AND SERVICE

- LINCOLN central lubrication for basic machine and attachment
- LINCOLN central lubrication for bucket and bucket stick assembly
- LINCOLN automatic pinion lubrication system for swing circle teeth
- WIGGINS service arm carrying fluid receiving connectors for filling of fuel, engine oil and coolant, hydraulic oil, grease, and the evacuation of coolant, hydraulic and engine oils

ACCESSORIES INCLUDED

- Acoustic travel alarm
- Hydraulically actuated ground access staircase
- 45° primary access and egress stairway
- 45° access swing stairway (hydraulically operated)
- 3 emergency egresses
 - cab and machinery house roof
 - machinery house escape
- Electric air horn
- Engine turbo and exhaust pipe covers
- Engine oil management package (Centinel, Reserve & Eliminator systems)
- Service transfer oil pump
- Hand rails and steps on boom
- Tie off points on boom
- Engine emergency stop at ground level



OPTIONAL EQUIPMENT

ATTACHMENT/BUCKET

- Alternative buckets on request
- Boom cylinder sliding guard
- Arm cylinder sliding guard
- Bucket cylinder sliding guard (BH)

UNDERCARRIAGE

- 1.900 mm 75" track shoes

POWER

- Electro drive various voltages
- Cable drum without cable
- Fire suppression system, Ansul (Agent LVS+Powder), diesel drive

COLD WEATHER

- Cold weather package down to -40° C (diesel and electro drive)
- Arctic weather package down to -50° C (diesel and electro drive)
- Hotstart temperature treatment for ambient temperature down to -50° C (diesel and electro drive), external power source not included

SPECIFIC HYDRAULIC OIL

- Biodegradable hydraulic oil

MISCELLANEOUS

- Camera system acc. ISO5006
- Additional LED working lights
- Rotaflare warning lights
- Additional cab A/C
- Additional independent cab heater
- Sound suppression kit
- Vibration monitoring for electro drive
- Service crane
- Sliders instead of top rollers
- Special painting



DIMENSIONS

BASIC MACHINE WITH COUNTERWEIGHT

A	1500 mm	4'11"	I	3437mm	11'3"
B	1900 mm	6'3"	J	3430mm	11'3"
C_A	8050 mm	26'5"	K	8304mm	27'3"
C_B	8450 mm	27'9"	L	9001mm	29'6"
D	2895 mm	9'6"	M	4480mm	14'8"
E	1065 mm	3'6"	N	3790mm	12'5"
F	3945 mm	12'11"	O	480mm	1'7"
G	7875 mm	25'10"	P	9620mm	31'7"
H	10510mm	34'6"	Q	7670mm	25'2"
			Q_R	7850mm	25'9"

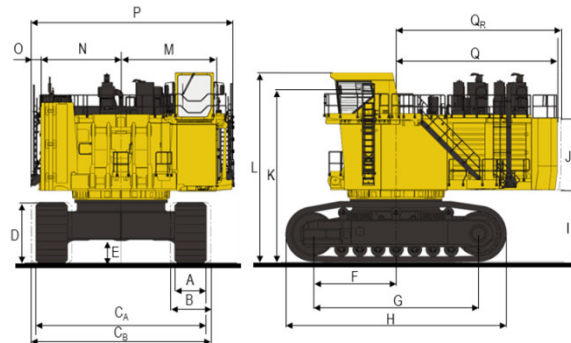

KOMATSU

Komatsu Mining Germany GmbH

Buscherhofstrasse 10, 40599 Duesseldorf, Germany

Phone: +49(0)211 71 09-0, Fax: +49(0)211 71 58-22

info@komatsu-mining.de, www.komatsu-mining.de



QESS007 00

© 2016 Komatsu Printed in Germany

Materials and specifications are subject to change without notice. Komatsu and KOMTRAX are registered trademarks of Komatsu Ltd., Japan / Photos may include optional equipment.