

KOMATSU®

D475A-5 With Tier 2 Engine

NET HORSEPOWER
664 kW **890 HP** @ 2000 rpm

OPERATING WEIGHT
108390 kg **238,960 lb**

D
475A

CRAWLER DOZER



Photos may include optional equipment.

WALK-AROUND

Komatsu-integrated design for the best value, reliability, and versatility. Hydraulics, power train, frame, and all other major components are engineered by Komatsu. You get a machine whose components are designed to work together for higher production, greater reliability, and more versatility.

The **Dual tilt dozer** increases productivity while reducing operator effort.

Hydraulic driven engine cooling fan controlled automatically, reduces fuel consumption and operating noise levels.

Extra-low machine profile provides excellent machine balance and low center of gravity.

Preventative maintenance

- Centralized Service Station
- Enclosed Hydraulic Piping
- Modular Power Train Design
- Oil Pressure Checking Ports

Automatic transmission with lockup torque converter increases speed and power to improve fuel consumption and productivity.

SAA12V140E-3 turbocharged aftercooled diesel engine provides a net output of 664 kW **890 HP** with excellent productivity. This machine is Tier 2 EPA, EU, and Japan emissions certified.

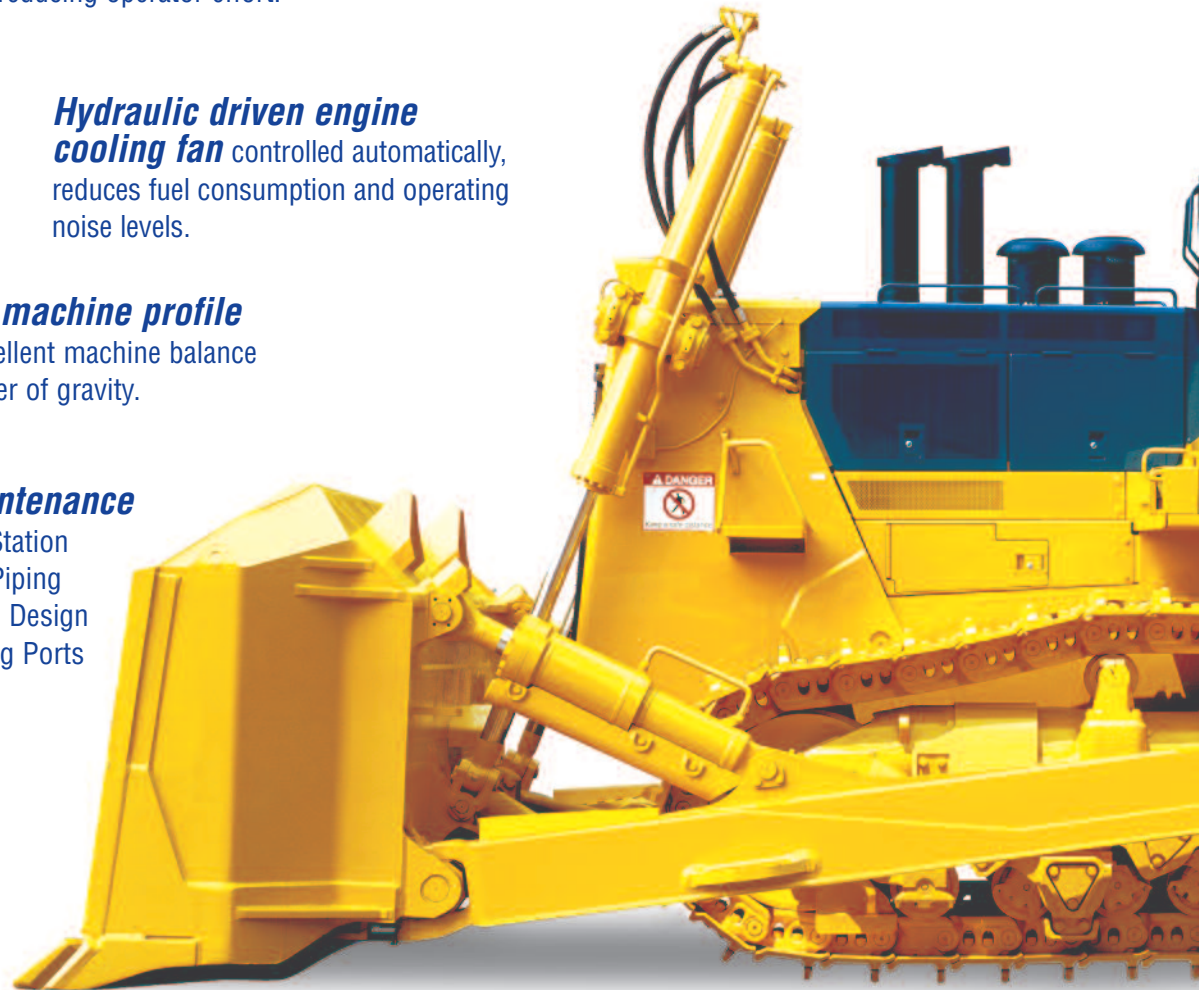

Large blade capacities:
27.2 m³ **35.6 yd³** (Semi-U dozer),
34.4 m³ **45.0 yd³** (U dozer), and
76 m³ **100 yd³** (Coal)

Track link with wedge ring reduces maintenance cost by making turning pins easier, with improved pin reuse.

Hexagonal designed cab includes:

- Spacious interior
- Comfortable ride with viscous cab damper mounting
- Excellent visibility
- High capacity air conditioning system
- Palm Command Control System (PCCS) joystick controls
- Pressurized cab
- Multi-position adjustable armrest
- Travel control console integrated with operator seat

NET HORSEPOWER
664 kW **890 HP** @ 2000 rpm

OPERATING WEIGHT
108390 kg **238,960 lb**

BLADE CAPACITY
Semi-U: 27.2 m³ **35.6 yd³**
Full-U: 34.4 m³ **45.0 yd³**
Coal : 76.4 m³ **100 yd³**

KOMTRAX Plus provides efficient monitoring of machine conditions for maximum productivity.

Low noise

- Operator noise: 70dB(A)
(Engine at Hi, cooling fan at 70%, and air conditioner OFF.)
- Dynamic noise (outside): 110dB(A)
As per ISO 6395

Electronic Controlled Modulation Valve (ECMV)

controlled steering clutch/brake system facilitates smooth and shockless steering operation.

Rear attachments (optional)

- Variable giant ripper
- Multi-shank ripper
- Counterweight

K-Bogie Undercarriage System improves traction, component durability, and operator comfort.



Photos may include optional equipment.

Track shoe slip control system

reduces operator fatigue and improves undercarriage life.

Low-drive, long-track, eight roller undercarriage

ensures outstanding dozing ability and stability.

CONTROL FEATURES

Komatsu's ergonomically designed control system "PCCS" creates an operating environment with "complete operator control."

Human-Machine Interface

Palm Command Electronic Controlled Travel Control Joystick

Ergonomically designed palm command travel joystick provides the operator with a relaxed posture and superb control improving operator comfort.

F/R One-Way Steer Lever

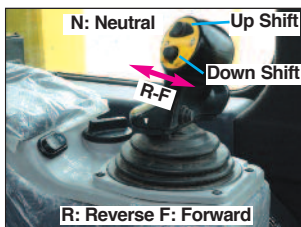

Blade and Ripper Control Joystick



Fully Adjustable Air Suspension Seat and Travel Control Console

For improved rear visibility during the return portion of the cycle, the operator can adjust the seat 15° to the right. The transmission and steering controls move with the seat for optimum operator comfort. The operator seat is also tiltable for facilitating down hill dozing. The travel control console is adjustable fore, aft, and for height.

Fuel Control Dial

Engine RPM is controlled by electric signals, providing ease of operation and eliminating maintenance of linkage and joints.

Palm Command PPC Controlled Blade Control Joystick

Blade control joystick uses the Proportional Pressure Control (PPC) valve and the same palm command type joystick, similar to the travel control joystick. PPC control, combined with the highly reliable Komatsu hydraulic system, enables superb control. Dual tilt and pitch operation are enabled by pressing a switch with the thumb.

Height Adjustable Blade Control Armrest

Blade control armrest is height adjustable without any tools in three stages, providing the operator with firm arm support and ideal comfort.

Position Adjustable Ripper Control Lever

Ripper control lever is adjustable, providing optimum operator posture for all operators during all types of ripping operations.

Air Suspension Seat



Outline of Electronic Control System

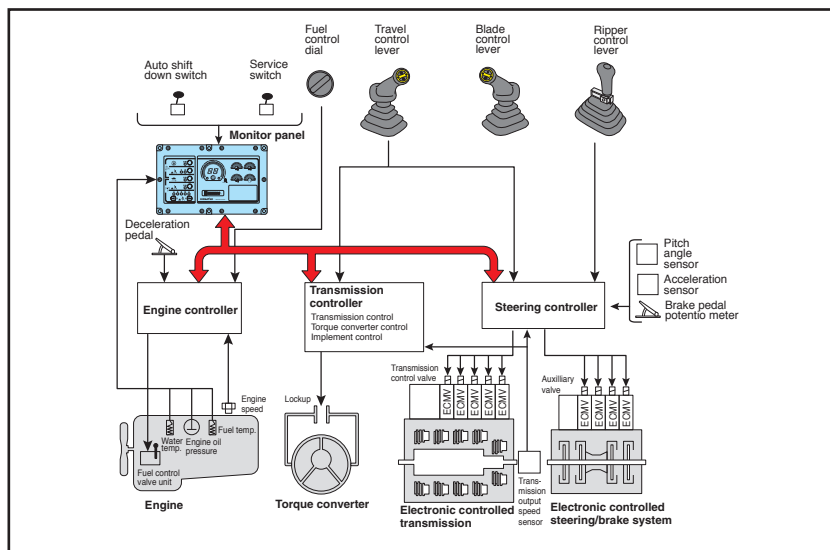

Power Train Electronic Control System

Smooth Operation

The D475A-5 utilizes a power train electronic control system. The controller registers the amount of operator control (movements of lever and operation of switches) along with machine condition signals from each sensor to accurately calculate the control of the torque converter, transmission, steering clutches and brakes for optimized machine operation. The ease of operation and productivity of the D475A-5 is greatly improved through these features.

Electronic Controlled Modulation Valve (ECMV) Controlled Transmission

Controller automatically adjusts each clutch engagement depending on travel conditions such as gear speed, RPM and shifting pattern. This provides shockless, smooth clutch engagement, improved component reliability, extended component life and operator ride comfort.

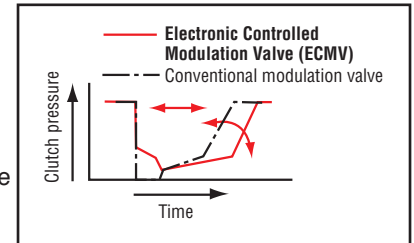

Electronic Controlled Modulation Valve (ECMV) Controlled Steering Clutches/Brakes

Sensors monitor machine operating conditions and electronically control steering clutches and brakes. Monitoring application parameters such as incline angle of slope and degree of load provide smooth and easy operation by reducing counter-steering on downhill travel, etc.

Effect of ECMV Steering Clutches/Brake Control

When dozing and turning, ECMV automatically controls stroke ratio of steering clutches and brakes depending on degree of load, enabling smooth dozing and turning.

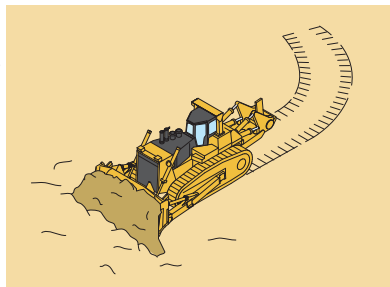

When dozing downhill, ECMV automatically controls steering clutches and brakes depending on incline of machine or degree of load, reducing counter-steering and producing smooth dozing operation.

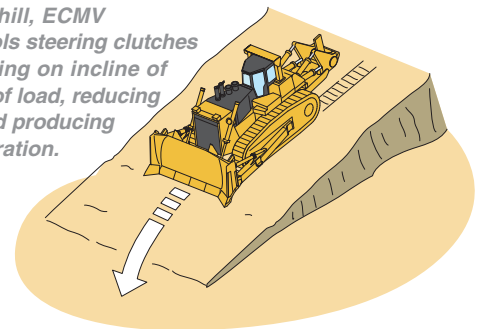

Preset Travel Speed Selection Function

Preset travel speed selection function is standard equipment, enabling the operator to select fore and aft travel speed among three preset patterns such as F1-R2, F2-R2 and manual shift. When F1-R2 or F2-R2 preset pattern is selected, and travel control joystick moves to forward/rearward direction, the machine travels forward/reverse with F1-R2 or F2-R2 speed automatically. This function reduces gear shifting time during repeated round-trip operations.

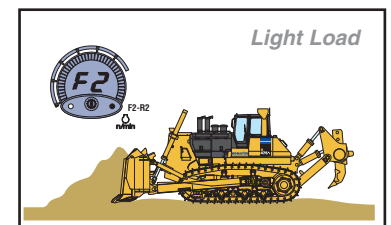
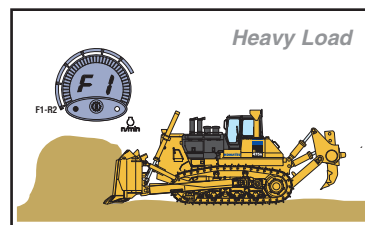
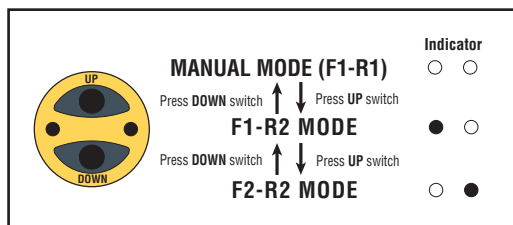

Auto Downshift Function

The controller monitors engine speed and travel speed. When load is applied and machine travel speed is reduced, the controller automatically downshifts to optimum gear speed to provide high fuel efficiency. This function provides comfortable operation and high productivity without manual downshifting.

Actuated with Heavy Load on Steep Slope

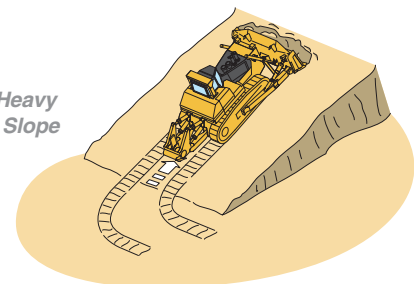

PRODUCTIVITY FEATURES

Engine

The Komatsu SAA12V140E-3 engine delivers a net output of 664 kW **890 HP** at 2000 rpm (SAE J1349). Productivity features, together with the heavy machine weight, make the D475A-5 a superior crawler dozer in both ripping and dozing production. The engine is Tier 2 EPA, EU, and Japan emissions certified and features direct fuel injection, turbocharger, and aftercooler to maximize fuel efficiency.

To minimize noise and vibration, the engine is mounted to the main frame with rubber cushions. For further convenience, fuel adjustment is unnecessary up to an altitude of 3000 m **9,840 ft**.

Hydraulic Driven Engine Cooling Fan

Fan rotation is automatically controlled depending on coolant and hydraulic oil temperature, saving fuel and providing increased productivity with a quiet operating environment. The fan has a reverse and a reverse/clean-out mode facilitating easier radiator maintenance.

Automatic Torque Converter Lockup System

For greater efficiency during long pushes, the lockup mode allows the system to automatically engage the torque converter lockup clutch. Locking up the torque converter transmits all the engine power directly to the transmission, increasing ground speed thus achieving efficiencies equal to a direct drive. The result is efficient use of engine power, less fuel consumption, and faster cycle times.

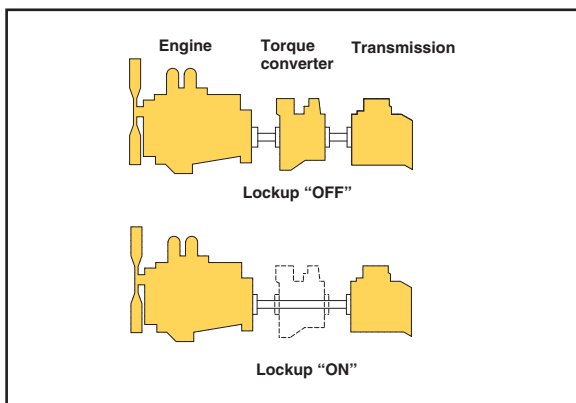

K-Bogie Undercarriage System

K-Bogies with front and rear single bogies are utilized to increase the length of track on ground improving machine stability and leveling performance. An oscillating idler and increased sprocket lead angle improve riding comfort when traveling over rough terrain. K-Bogies oscillate with two fulcrums assuring a large amount of track roller vertical travel. Impact load to undercarriage components is minimized and durability of components is improved since track rollers are always in contact with track links. Track rollers follow track link movement to extend the undercarriage life. Excellent riding comfort is provided due to less vibration and shock when traveling over rough terrain.

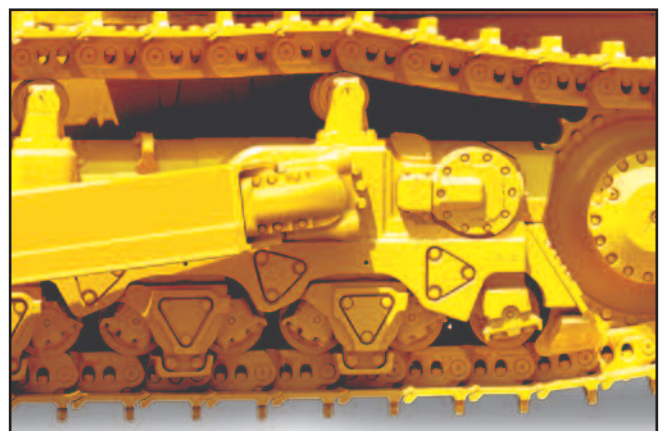
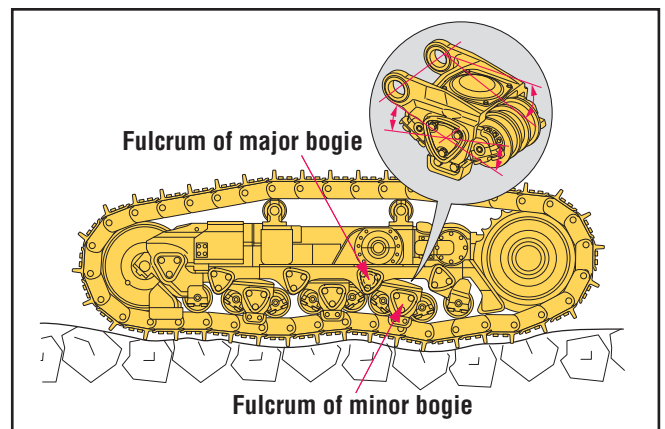

Large Blade

Capacities of 27.2 m³ **35.6 yd³** (Semi-U dozer), 34.4 m³ **45.0 yd³** (U dozer), and 76.4m³ **100 yd³** (coal) yield outstanding production. High-tensile-strength steel has been incorporated into the front and sides of the blade for increased durability

Dual Tilt Dozer

The dual tilt dozer increases productivity while reducing operator effort

- Optimum blade cutting angle for all types of materials and grades can be selected on-the-go for increased load and production
- Digging, hauling, and dumping are easy and smooth with less operator fatigue
- Dozer tilt angle and tilt speed are twice that of a conventional single tilt system

Rippers (optional)

- The variable giant ripper features a long sprocket center-to-ripper point distance, making ripping operation easy and effective while maintaining high penetration force
- The variable giant ripper is a parallelogram single shank ripper ideal for ripping up tough material. The ripping angle is variable, and the depth is adjustable in four stages by a hydraulically controlled pin puller
- The multi-shank ripper is a hydraulically controlled parallelogram ripper with three shanks. The ripping angle is variable and depth is adjustable in two stages



Track Shoe Slip Control Mode

Eliminates the need for the operator to constantly control engine power output with the decelerator pedal while ripping substantially reducing operator fatigue. Maneuverability is improved because the operator is free to focus on the ripping application without having to monitor the track shoe slippage. Repair costs are significantly lowered and undercarriage life is extended with the reduction in track shoe slippage. The track shoe slip control system will contribute to lower fuel costs because the engine output is automatically controlled to optimum levels for operation.

Track Shoe Slip Control Panel

WORKING ENVIRONMENT

Work Environment

Operator comfort is essential for productive work. The D475A-5 provides the operator with a quiet, comfortable environment where the operator can concentrate on the work at hand.

Hexagonal Pressurized Cab

- The cab's hexagonal design and large tinted glass windows provide excellent front, side, and rear visibility.
- Improved cab sealing, air filters and increased internal air pressure combine to help prevent dust from entering the cab.
- The floor mat and door sill are the same height to facilitate easy cleaning.
- The high quality cab interior is fully lined with sound absorbing material.

Comfortable Ride with Cab Damper Mounting and K-Bogie Undercarriage

D475A-5's cab mount uses a cab damper mounting which provides excellent shock and vibration absorption capacity with its long stroke. The cab damper mounting, combined with K-bogie undercarriage, softens shocks and vibrations while traveling over adverse conditions. The soft spring cab damper isolates the cab from machine body, suppressing vibrations and providing a quiet, comfortable operating environment.

Low Sound Levels

The D475A-5 features a unique and unrivaled low noise design. This is accomplished by improvements not only in the cab but throughout the machine. The cab features an insulated double floor to reduce power train noise, thicker glass in the door and increased pressurization from improved window seals. Engineered baffles on the machine absorb and reduce the fan noise. Cool air inlet ducts are lined with sound absorbing material that direct the air to the hydraulic fan and a double insulated engine hood with additional sound absorbing material further reduce engine noise. These improvements help the D475A-5 achieve remarkably low sound levels.

- Operator noise: 70dB(A) (Engine at high idle, fan speed at 70%, and air conditioner OFF)
- Dynamic noise (outside): 110dB(A) (As per ISO 6395)

Improved Visibility in Rear of Blade

The shape of the blade heel and the position of the operator's seat are changed so that the operator can check the ground in the rear of the blade during dozing. Accordingly, the operator can work more accurately. In addition, the position of the exhaust pipe is changed for better front visibility.

Air Intake Ports of Air Conditioner

The air conditioner fresh air inlet is located above the fender to help prevent dust from the undercarriage from entering the cab. The inside air recirculation inlet is located behind the operator's seat, away from the dirt and dust of the floor mat, to provide an increased cleaning/replacement interval.



Cab Damper Mounting

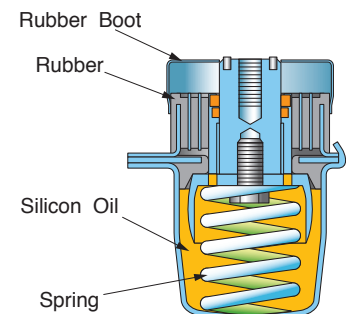

EASY MAINTENANCE

Preventative Maintenance

Preventative maintenance is the only way to ensure long service life from your equipment. That's why Komatsu designed the D475A-5 with conveniently located maintenance points to make necessary inspections and maintenance quick and easy.

Centralized Service Station

To ensure convenient maintenance, the transmission and torque converter oil filters are both arranged next to the power train oil level gauge.

Monitor with Self-Diagnostic Function

If the monitor finds abnormalities, a corresponding warning lamp blinks and a warning buzzer sounds to help prevent the



development of serious problems. When abnormalities occur during operation, a service user code is displayed.

Gull-wing Engine Side Covers

Dual insulated gull-wing engine side covers facilitate engine maintenance and filter replacement. Side covers are thick two-piece structures with bolt-on latches to improve durability and repairability.

Low Maintenance Costs

Track Link with Wedge Ring

The D475A-5 Dozer track links feature reduced press-fit force and a wedge ring. Conventional track pins are retained only with a large press-fit force. (The track link divides pin forces between the wedge ring and press-fit force.) This enables easier service with reduced pin damage when turning pins and bushings. The result is improved undercarriage life and reduced maintenance cost through reduced wear, greater pin reusability, and reduced maintenance man-hours.

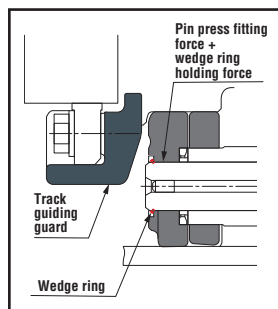

Highly Reliable Electric Circuit

The electrical circuit reliability is increased by utilizing dust, vibration and corrosion resistant "DT connectors". The reinforced electrical wiring harnesses include circuit breakers and are covered with a heat-resistant material to increase mechanical strength, provide longer life, and protect the system from damage.

Oil Pressure Checking Ports

Pressure checking ports for power train components are centralized to promote quick and simple diagnosis.

KOMTRAX Plus

As part of a complete service and support program, Komatsu equips every mining and quarry sized machine with KOMTRAX Plus. By using a satellite-based communication system, KOMTRAX Plus offers a new vision of monitoring your valuable assets by providing insight to critical operating metrics and information that can be used to increase availability, lower owning and operating costs and maximize fuel efficiency.

The KOMTRAX Plus information available on MyKomatsu.com allows service personnel and asset owners to review cautions, operational data, fuel consumption, payloads and key component measurements provided in forms of trends. With KOMTRAX Plus, knowledge becomes the power to fuel your productivity.



Flat Face O-Ring Seals

Flat face O-ring seals are used to securely seal all hydraulic hose connections and to help prevent oil leakage.

Enclosed Hydraulic Piping

Hydraulic piping for the blade tilt cylinder is completely housed in the push arm protecting it from damage.

Modular Power Train Design

Power train components are sealed in a modular design that allows the components to be removed and replaced without oil spillage, making servicing work clean, smooth, and easy.

Maintenance-Free Disc Brakes

Wet disc brakes are adjustment free and provide excellent service life.

MINING SPECIFICATIONS FOR EASY MAINTENANCE

Manual Engine Shutdown Switches

In case of urgent need to stop the engine, two shutdown switches are provided, in the cab and at the right rear of the machine.



Switch location (inside the cab)



Switch location (at the rear)

Uninterrupted Power Source

Uninterrupted power source allows for 2-way radio communication at any time. (Interior lights can be turned on with the starting switch at OFF position.)

Access Lights

Access lights are installed at the front (2, right and left) and (1) at the rear of the machine.



Work Light for the Engine Compartment

A work light is installed inside the engine hood (left side) to facilitate night-time inspection and maintenance.



Provision for Platforms

Provision for platforms eliminates the need to modify the machine for future installation of platforms.

Platforms with Handrails and Foot Barriers

Optional platforms can be ordered to give access to the side faces and the rear of the machine.

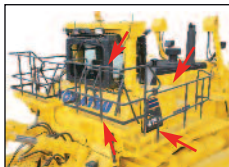

Hood Mounted Hand Rails with Anti-Slip Plate

Optional platforms can be ordered to surround the hood area to give access to radiator water level and work lights.

Isolator Box

Battery and starting motor isolators are housed in the isolator box on the left side of the machine to facilitate cut-off of the battery circuit for maintenance of the machine. Jump-start connectors are also provided in the box in case of power failure.

- A : Starter isolator
- B : Jump start receptacle
- C : Battery isolator

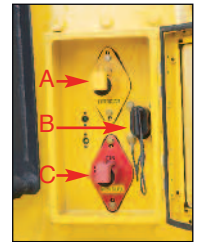

Canister-type Breathers

Canister-type breathers are remotely arranged inside the left exterior cover to facilitate check and cleaning of the breather of each component.

- A : Power train case
- B : Flywheel housing
- C : Damper case

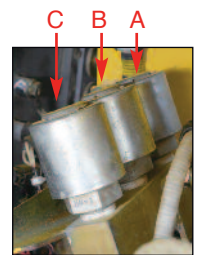

Maintenance Service Center

Couplings (made by Wiggins) installed at the rear left of the machine enable quick drain and change of oil and coolant. The Fast Fuel Fill (also by Wiggins) enables refueling from ground level. The service center eliminates the need to get on/off the machine and to remove/install covers to perform fluid maintenance.

- A : Engine oil
- B : Radiator coolant
- C : Transmission oil
- D : Hydraulic oil
- E : Fast Fuel Fill

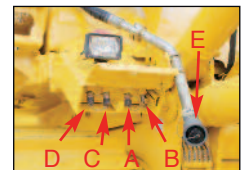

Concentrated Sampling Points

Concentrated sampling points are remotely arranged in the tool box storage area to facilitate sampling of the oil and coolant from each component.

- A : Engine oil
- B : Radiator coolant
- C : Transmission oil
- D : Hydraulic oil

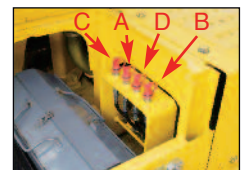

Centralized Grease Points for Blade Cylinder Yoke and Ripper Mount Pin

Centralized grease points enable lubrication of both blade and ripper from ground level.



SPECIFICATIONS



ENGINE

Model Komatsu SAA12V140E-3
 Type 4-stroke, water-cooled, direct injection
 Aspiration Turbocharged, air-to-air aftercooled
 Number of cylinders 12
 Bore x stroke 140 mm x 165 mm **5.51" x 6.50"**
 Piston displacement 30.48 ltr **1,860 in³**
 Horsepower
 SAE J1349 671 kW **899 HP**
 DIN6270 664 kW **890 HP**
 Hydraulic fan at maximum speed 641 kW **860 HP**
 Rated rpm 2000 rpm
 Governor All-speed, electronic
 Lubrication system
 Method Gear pump, force lubrication
 Filter Full-flow and bypass combined



TORQFLOW TRANSMISSION

Komatsu TORQFLOW transmission consists of a water-cooled, 3-element, 1-stage, 1-phase torque converter with lockup clutch and a planetary gear, multiple-disc clutch transmission which is hydraulically-actuated and force-lubricated for optimum heat dissipation. Gearshift lock lever and neutral safety switch help prevent accidental starts.

Gear	Forward		Reverse	
	km/h	mph	km/h	mph
1st	3.3	2.1	4.2	2.6
2nd	6.2	3.9	8.0	5.0
3rd	11.2	7.0	14.0	8.7

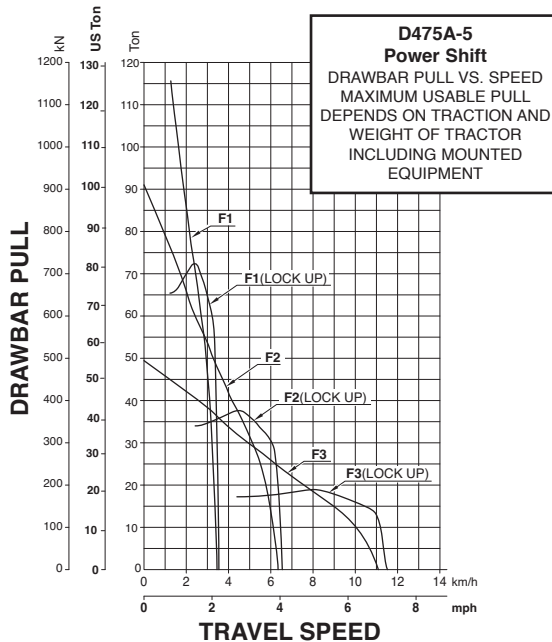

FINAL DRIVES

Double-reduction final drive of spur and planetary gear sets to increase tractive effort and reduce gear tooth stresses for long final drive life. Segmented sprocket teeth are bolt-on for easy replacement.



STEERING SYSTEM

PCCS lever, joystick-controlled, wet multiple-disc steering clutches are spring-loaded and hydraulically released. Wet multiple-disc steering brakes are spring-actuated, hydraulically released, and require no adjustment. Steering clutches and brakes are interconnected for easy, responsive steering.

Minimum turning radius 4.6 m **15'1"**



UNDERCARRIAGE

Suspension Oscillating equalizer bar and pivot shaft
 Track roller frame Cylindrical, high-tensile-strength steel construction
 Rollers and idlers Lubricated track rollers

K-Bogie Undercarriage

Lubricated track rollers are resiliently mounted to the track frame with a bogie suspension system whose oscillating motion is cushioned by rubber pads.

Extreme Service Track Shoes

Lubricated tracks. Unique seals prevent entry of foreign abrasives into pin to bushing clearances to provide extended service life. Track tension is easily adjusted with grease gun.

Number of shoes (each side) 41
 Grouser height:

Single grouser 105 mm **4.1"**
 Shoe width (standard) 710 mm **28"**
 Ground contact area 64240 cm² **9,957 in²**
 Ground pressure (Tractor) 128 kPa 1.30 kg/cm² **18.5 psi**
 Number of track rollers 8
 Number of carrier rollers 2

Extreme service shoes	Additional weight	Ground contact area	Ground** pressure
710 mm 28"	0 kg 0 lb	64240 cm² 9,957 in²	128 kPa 1.30 kgf/cm² 18.5 psi
810 mm 32"	920 kg 2,030 lb	73290 cm² 11,360 in²	113 kPa 1.15 kgf/cm² 16.4 psi
910 mm 36"	1830 kg 4,030 lb	82340 cm² 12,762 in²	102 kPa 1.04 kgf/cm² 14.8 psi

** Ground pressure based on tractor, Semi-U tilt dozer, giant ripper, cab, ROPS, operator, standard equipment, rated capacity of lubricant, coolant, and full fuel tank.



SERVICE REFILL CAPACITIES

Fuel tank 1670 ltr **441 U.S. gal**
 Coolant 275 ltr **72.6 U.S. gal**
 Engine 121 ltr **32.0 U.S. gal**
 Torque converter, transmission,
 bevel gear, and steering system 210 ltr **55.5 U.S. gal**
 Final drive (each side) 75 ltr **19.8 U.S. gal**



DIMENSIONS

SEMI-U DOZER WITH GIANT RIPPER

A	2770 mm	9'1"
B	5265 mm	17'3"
C	4546 mm	14'11"
D	2690 mm	8'10"
E	4524 mm	14'10"
F	11565 mm	37'11"
G	3720 mm	12'2"
H	1744 mm	5'9"
I	1196 mm	3'11"
J	4646 mm	15'3"

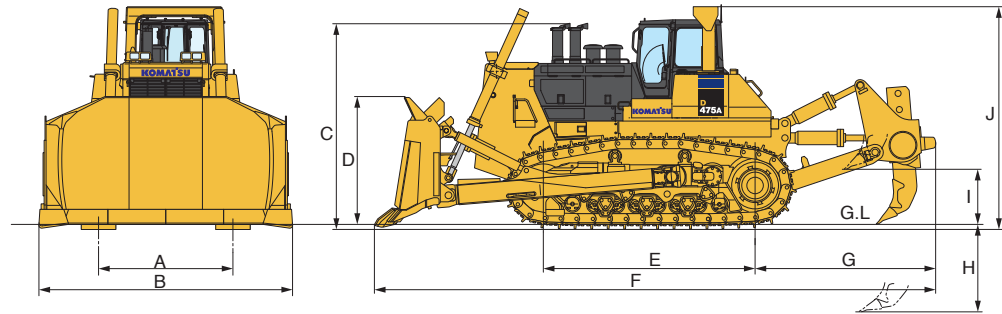

Ground Clearance: 655 mm 2'2"



OPERATING WEIGHT

Tractor weight 83590 kg **184,290 lb**
Including rated capacity of lubricant, coolant, full fuel tank, operator, and standard equipment.

Operating weight 108390 kg **238,960 lb**
Including strengthened Full-U tilt dozer, giant ripper, steel cab, ROPS, operator, standard equipment, rated capacity of lubricant, coolant, and full fuel tank.

Ground pressure 166 kPa 1.69 kg/cm² **24.0 psi**



HYDRAULIC SYSTEM

Closed-center load sensing system (CLSS) designed for precise and responsive control, and for efficient simultaneous operation.

Hydraulic control units:
All spool valves externally mounted beside the hydraulic tank.
Plunger type hydraulic pump with capacity (discharge flow) of 542 ltr/min **143 U.S. gal/min** at rated engine rpm.

Relief valve setting 27.5 MPa 280 kg/cm² **3,980 psi**

Control valves:
Spool control valves for Semi-U tilt dozer and Full-U tilt dozer
Positions: Blade lift Raise, hold, lower, and float
Blade tilt Right, hold, and left

Spool control valves for variable digging angle multi-shank ripper and giant ripper.
Positions: Ripper lift Raise, hold, and lower
Ripper tilt Increase, hold, and decrease

Hydraulic cylinders Double-acting, piston

	Number of cylinders	Bore
Blade lift	2	180 mm 7.09"
Blade tilt	1	250 mm 9.84"
Ripper lift	2	225 mm 8.86"
Ripper tilt	2	225 mm 8.86"

Hydraulic oil capacity (refill):
Semi-U tilt dozer 180 ltr **48 U.S. gal**
U tilt dozer 180 ltr **48 U.S. gal**
Ripper equipment (additional volume):
Giant ripper (variable) 130 ltr **34 U.S. gal**
Multi-shank ripper 130 ltr **34 U.S. gal**



DOZER EQUIPMENT

Blade capacities are based on the SAE recommended practice J1265.

	Overall length with dozer	Blade capacity	Blade length x height	Maximum lift above ground	Maximum drop below ground	Maximum tilt adjustment	Weight	Ground pressure*
							Dozer equipment	
Semi-U dozer	8705 mm 28'7"	27.2 m ³ 35.6 yd³	5265 mm x 2690 mm 17'3" x 8'10"	1620 mm 5'4"	1010 mm 3'4"	770 mm 2'6"	16500 kg 36,376 lb	166 kPa 1.69 kg/cm ² 24.0 psi
U dozer	9205 mm 30'2"	34.4 m ³ 45.0 yd³	6205 mm x 2610 mm 20'4" x 8'7"	1620 mm 5'4"	1010 mm 3'4"	905 mm 3'	18800 kg 41,446 lb	169 kPa 1.72 kg/cm ² 24.5 psi
Dual tilt Semi-U dozer	8705 mm 28'7"	27.2 m ³ 35.6 yd³	5265 mm x 2690 mm 17'3" x 8'10"	1620 mm 5'4"	1010 mm 3'4"	1145 mm 3'9"	16950 kg 37,368 lb	166 kPa 1.69 kg/cm ² 24.0 psi
Dual tilt U dozer	9205 mm 30'2"	34.4 m ³ 45.0 yd³	6205 mm x 2610 mm 20'4" x 8'7"	1620 mm 5'4"	1010 mm 3'4"	1350 mm 4'5"	19250 kg 42,439 lb	170 kPa 1.73 kg/cm ² 24.3 psi

*Ground pressure shows tractor, cab, ROPS canopy, operator, giant ripper, standard equipment, and applicable blade.



STANDARD EQUIPMENT

- -30°C cold weather package
- Accessory sockets, 2 x 12V
- Additional front and rear work lights
- Air conditioner with heater and defroster
- Alternator, 90 ampere/24V
- Auto-priming system
- Back-up alarm
- Batteries, 4 x 12 V, 200 Ah
- Batteries and starter isolator box
- Blower cooling fan
- Cab light uninterrupted power source
- Canister-type breathers
- Centralized grease points, blade cylinder yoke
- Centralized grease points, ripper mount pin
- Concentrated sampling points for oil and coolant
- Decelerator pedal
- Double door wiper
- Dry-type air cleaner with dust evacuator and dust indicator
- Dual tilt dozer
- Eight-roller track frames
- Engine oil level sensor
- Engine prelubrication system
- F/R one-way steering lever
- Fast fuel fill
- Final drive case wear guard
- Final drive seal guards
- Heavy duty wiring harness
- Hinged front mask
- Hinged underguard with front pull hook
- Hydraulics for ripper
- Hydraulic track adjusters
- K-Bogie Undercarriage System
- KOMTRAX Plus
- LED work lights
- Lighting system (six front/two rear)
- Light for ripper
- Lockup torque converter
- Lunch box holder
- Maintenance service center for oil and coolant
- Manual engine stop switches
- Mirror, rear view
- Muffler with rain cap
- PCCS palm lever steering control
- Perforated front mask
- Provision for platforms
- Radiator reserve tank
- Radio, AM/FM cassette
- Ride comfort upgrade package
- ROPS, Heavy Duty
- Seat belt, 78 mm, 3"
- Seat, air suspension, fabric, high back, fully adjustable
- Segmented sprockets
- Shoes, 710 mm 28" extreme service, single-grouser
- Starting motors, 2 x 7.5 kW/24V
- Steel cab
- Steps, heavy-duty and handles
- Sun visor
- TORQFLOW transmission
- Track roller guards
- Track shoe slip control system
- Warning horn
- Water separator
- Wet steering clutches
- Working light for the engine compartment

ROPS:*Weight 940 kg **2,070 lb**

Roof dimensions:

Width 1940 mm **6'4"**

Height from

compartment floor 1872 mm **6'2"**

*Meets ISO 3471 and SAE J1040 APR88, ROPS standards

Steel cab:*Weight 455 kg **1,000 lb**

Dimensions:

Length 1790 mm **5'10"**Width 1455 mm **4'9"**

Height from compartment

floor to ceiling 1530 mm **5'0"**

*Meets ISO 3449 FOPS standard



OPTIONAL EQUIPMENT

- Additional cab heater
- Coal dozer
- Counterweight
- Hitch
- Hood handrails
- Panel cover
- Platforms- left hand side only
- Platforms with handrails and foot barriers- right and left side
- Pusher plate
- Spill guard for Full-U dozer
- Spill guard for Semi-U dozer
- Shoes, extreme service, single-grouser:
 - 810 mm **32"**
 - 910 mm **36"**
- Strengthened Semi-U blade
- Strengthened Full U blade

Multi-shank ripper:

Hydraulically controlled parallelogram ripper with three shanks. Ripping angle is steplessly adjustable.

Weight (including hydraulic control unit and oil) 9720 kg **21,430 lb**

Beam length. 3085 mm **10'1"**

Maximum lift above ground . 1196 mm **3'11"**

Maximum digging depth. 1124 mm **3'8"**

Variable giant ripper:

Variable, parallelogram single-shank ripper ideal for ripping up tough material. Ripping angle is variable. Ripping depth is adjustable in three stages by a hydraulically controlled pin puller.

Weight (including hydraulic control unit and oil) 7360 kg **16,226 lb**

Beam length. 1477 mm **4'10"**

Maximum lift above ground . 1196 mm **3'11"**

Maximum digging depth 1744 mm **5'9"**

Note: ProVision High Precision GPS Grade Level System is available from Modular Mining

KOMATSU[®]

