

KOMATSU

PC3000-6 Loading Shovel PC3000-6 Backhoe

ENGINE POWER

940 kW / 1260 HP @ 1800 rpm

OPERATING WEIGHT

250 – 261 ton / 511,300 – 575,500 lb

SHOVEL CAPACITY

16 m³ 21 yd³ SAE 2:1 heaped

BACKHOE CAPACITY

15 m³ 19.5 yd³ SAE 1:1 heaped

PC
3000

HYDRAULIC EXCAVATOR



WALK-AROUND



Quality in Manufacturing

Commitment to „Quality and Reliability“

- Quality management ISO 9001
- Environmental management ISO 14001
- Occupational health and safety management system BS OHSAS 18001:2007
- High consistent quality through continuous investment in personnel, design and manufacturing systems and processes

Powerful Diesel Engine

Version 1 - Komatsu SSA12V159 (Tier 1)

Version 2 - Komatsu SDA12V159E-2 (Tier 2)

- Rated 940 kW / 1260 HP at 1800 rpm
- Electronic engine management
- Low engine emission levels
- Optional time saving Engine Oil Management System; Centinel, Engine Reserve Oil Supply and Eliminator Oil Filter System

Reliability and Durability

Long life and low operating cost by design

- Robust structural design developed from field experience and finite element analysis

Undercarriage

- Large diameter rollers, idlers and sprockets
- Large surface area and extensive precision hardening of all engaging components reduce track wear
- Hardened track link pin bores

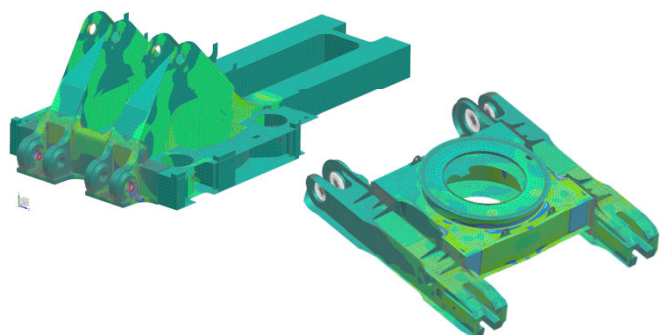

Productivity

Designed for more tons per hour

- Powerful digging forces
- Ease of bucket filling
- Proven attachment design
- All cylinders mounted in the shadow of the attachment for protection
- Various buckets and wear packages to suit all material densities and properties

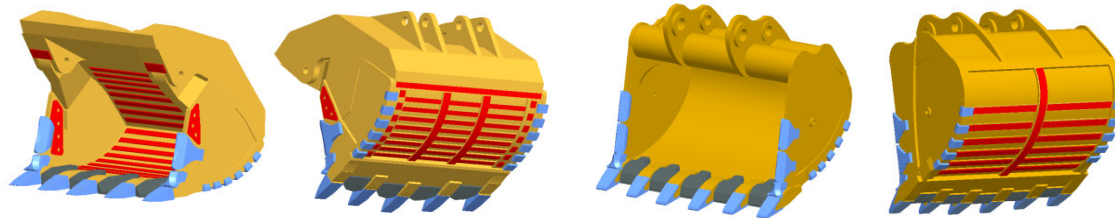

MATCHES

85 to 165 U.S. ton TRUCKS

OPERATING WEIGHT

Shovel 250-258 ton
551,300-568,900 lb

Backhoe 252-261 ton
555,700-575,500 lb

BUCKET CAPACITY

Shovel 16 m³ 21 yd³
Backhoe 15 m³ 19.5 yd³

Advanced Hydraulics

Extended reliability and precise control

- Electronic pump management
- Comprehensive monitored filtration
- Simple open circuit hydraulic system with high efficiency swing out oil coolers

Large Comfortable Cab

Comfortable for the whole day

- Komatsu low noise cab on multiple viscous mounts for reduced noise and vibration
- Large volume cab with full height front window
- Comprehensive climate control with pressurised filtered air ventilation and air conditioning
- High specification multi-adjustable air suspension seat plus trainer seat
- Well elevated operator position giving good all round view
- Large twin wiper covers windshield area for excellent visibility

Easy and Safe Maintenance

Simple, common-sense design provides easy access to all major components

- Generous access to all major service points from machinery house floor level
- Enclosed, walk-in machinery house with partition wall separating engine from pump area
- Automatic central lubrication
- KOMTRAX Plus electronic monitoring system providing real time information about the operating status of the machine
- Ground-level access to hydraulically powered swing down service arm with Wiggins connections
- Acknowledges EMESRT design philosophies

SPECIFICATIONS



DIESEL DRIVE

Version 1 - Tier 1 engine:

Model Komatsu SSA12V159
 Type 4-cycle, water-cooled, direct injection
 Aspiration Turbocharged and aftercooled
 Number of cylinders 12
 Rated power 940 kW 1260 HP @ 1800 rpm
 (SAE 1995/J1349)
 Governor All-speed, electronic

Version 2 - Tier 2 engine:

Model Komatsu SDA12V159E-2, Tier 2 certificated
 Type 4-cycle, water-cooled, direct injection
 Aspiration Turbocharged and aftercooled
 Number of cylinders 12
 Rated power 940 kW 1260 HP @ 1800 rpm
 (SAE 1995/J1349)
 Governor All-speed, electronic

Optional engine oil management system:

The integrated engine oil and filter system combining the oil stabilising systems, Reserve and Centinel, with Eliminator oil filter extends the oil change interval up to 4.000 hours based on oil analysis.



ELECTRIC DRIVE

Type Squirrel cage induction motor
 Power Output 900 kW
 Voltage 6.000 – 7.200 V*
 Amperage (approximate) 96 A - 80 A
 Frequency standard 60 Hz @ 1800 rpm
 Frequency option 50 Hz @ 1500 rpm
 * Other voltages available on request



ELECTRIC SYSTEM

System 24 V
 Batteries (series/parallel) 4 x 12 V
 Alternator 140 A
 Standard working lights 12 Xenon lights
 Standard service lights throughout the platform



UNDERCARRIAGE

Track Adjustment Automatic hydraulic type
 Number of track shoes 46 each side
 Number of top rollers 3 each side
 Number of bottom rollers 7 each side



TRAVEL AND BRAKE SYSTEMS

Travel control 2 foot pedals
 Gradeability Up to 57 %
 Travel speed (maximum) 2,4 km/h 1.5 mph
 Service brake Hydraulic brake
 Parking brake Wet, multiple-disk



SWING SYSTEM

Hydraulic motors and drives 1
 Swing brake, service Hydraulic brake
 Swing brake, parking Wet, multiple-disc
 Swing ring teeth External
 Swing speed (maximum) 4.6 rpm



HYDRAULIC SYSTEM

The power train consists of one main drive. Diesel or electric motor can be supplied. One gearbox drives three identical main pumps which draw hydraulic oil from an unpressurised hydraulic tank. Open circuit hydraulics provide maximum cooling and filtering efficiency.

Main hydraulic pumps 3 x 910 ltr/min / 3 x 250 gpm
 Relief valve setting 310 bar / 4,495 psi
 Swing flow rate 800 ltr/min / 211 gpm
 High pressure in line filters 200 microns
 one per pump located at the valve blocks

Full flow return line filters 3 x 10 microns and leakage line filter 3 microns all with monitored 200 microns by pass filters. The three-circuit system features a load-limiting governor with oil delivery summation to the working circuits and incorporates pressure cut-off control. Hydroplit prioritises hydraulic flow giving smooth hydraulic response, simple hydraulic system layout, and a reduced number of components.



AUTOMATIC CENTRALISED LUBRICATION

Two hydraulically powered Lincoln single line automatic lubrication systems are provided as standard, complete with time and volume variable controls. The central lube grease system is supplied from a refillable 200 litre (53 gal.) barrel. A second, identical system supplies open gear lubricant to the swing ring teeth through a lube pinion. Replenishment of the barrels is through the service arm.



SERVICE CAPACITIES

Hydraulic oil tank 2.670 ltr / 705 U.S. gal
 Hydraulic system 4.400 ltr / 1,160 U.S. gal
 Fuel 4.500 ltr / 1,190 U.S. gal
 Engine coolant 254 ltr / 67 U.S. gal
 Engine oil 190 ltr / 50 U.S. gal

OPERATOR CAB

The large and comfortable cab is mounted on 15 viscous damping pads and sound insulated. The cab has automatic climate control and is pressurised. The operator's seat is air suspended, electrically heated and has a lap seat belt and offers multiple adjustments. The trainer seat is also equipped with a seat belt. Low-effort hydraulic joystick controls are combined with foot controls for front shovel clam, crawler and swing brake. Full instrumentation, KOMTRAX Plus and an AM/FM radio with MP3 ready CD player is fitted. Two windshield wash wipers are synchronised and have two speeds and intermittent operation. Two heated rear view mirrors are externally mounted. External metal sun blinds on the cab side windows and internal roller blinds on all windows are standard. There is a left hand sliding window. All windows are tinted parsol green. A walkway is mounted in front of cabin. (Subject to change without notice)

Major cab engineering standards are:

- ISO 3449 Falling Objects Protection Structure (FOPS)
- ISO 6396 Noise in operator's cab is max. 77 dB(A)
- ISO 2631-1 Whole body vibration and shock below 0,5 m/s²
- ISO 5349-1 Hand-lever vibration lower than 2,5 m/s²
- ISO 10263-4 Heating and air conditioning second heater or air conditioner as option

KOMTRAX PLUS HEALTH MONITORING SYSTEM

The KOMTRAX Plus monitoring system is designed for Komatsu mining equipment to provide real time and stored information about the operating status of the machine. Fault messages are immediately available to the operator via a digital display and in the event of critical malfunctions the engine is also shut down. The digital storage provides failure summary and analysis, which can be down loaded by laptop computer. This data will assist in predicting or reduction downtime.

OPERATING WEIGHTS (APPROXIMATE)

PC 3000 Backhoe:

Operating weight including 8.600 mm 28'3" boom, 4.000 mm 13'1" stick, 15 m³ (19.5 yd³) backhoe bucket, operator, lubricant, coolant, 1/3 fuel and standard equipment.

Shoe Width	Operating Weight	Ground Pressure
800 mm 31"	252 t 555,700 lb	23,2 N/cm ² 33.6 psi
1.000 mm 39"	261 t 575,500 lb	19,2 N/cm ² 26.5 psi
1.200 mm 47"	261 t 575,500 lb	16,0 N/cm ² 23.2 psi

PC 3000 Front Shovel:

Operating weight including 6.000 mm 19'8" boom, 4.300 mm 14'1" stick, 16 m³ (21 yd³) shovel bucket, operator, lubricant, coolant, 1/3 fuel and standard equipment.

Shoe Width	Operating Weight	Ground Pressure
800 mm 31"	250 t 551,300 lb	22,9 N/cm ² 33.2 psi
1.000 mm 39"	258 t 568,900 lb	19,0 N/cm ² 27.5 psi
1.200 mm 47"	258 t 568,900 lb	15,8 N/cm ² 22.9 psi

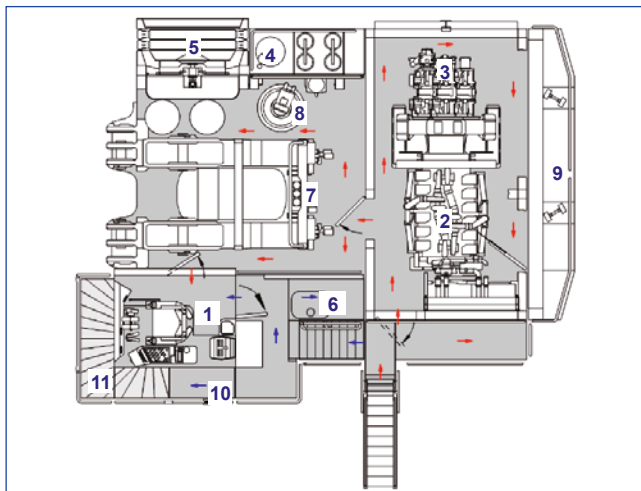

Diesel Drive

- | | |
|---------------------|-------------------------|
| 1 Cab | 7 Valve Blocks |
| 2 Diesel Engine | 8 Swing Motors |
| 3 Hydraulic Pumps | 9 Counterweight |
| 4 Hydraulic Tank | 10 Emergency egress |
| 5 Hydraulic Coolers | 11 See-through Cat Walk |
| 6 Fuel Tank | |

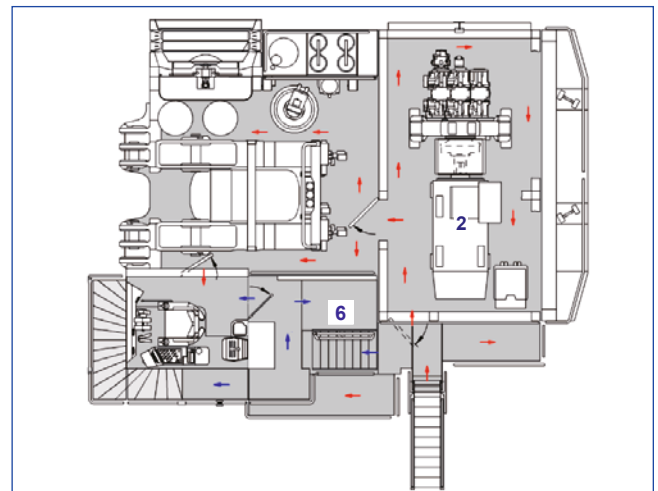

Variation for Electric Drive Version

- | |
|---------------------------------|
| 2 Electric Motor |
| 6 High Voltage Electric Cabinet |

Walkways ← Lower-Level
← Upper-Level

PRODUCTIVITY-FEATURES

BACKHOE ATTACHMENT

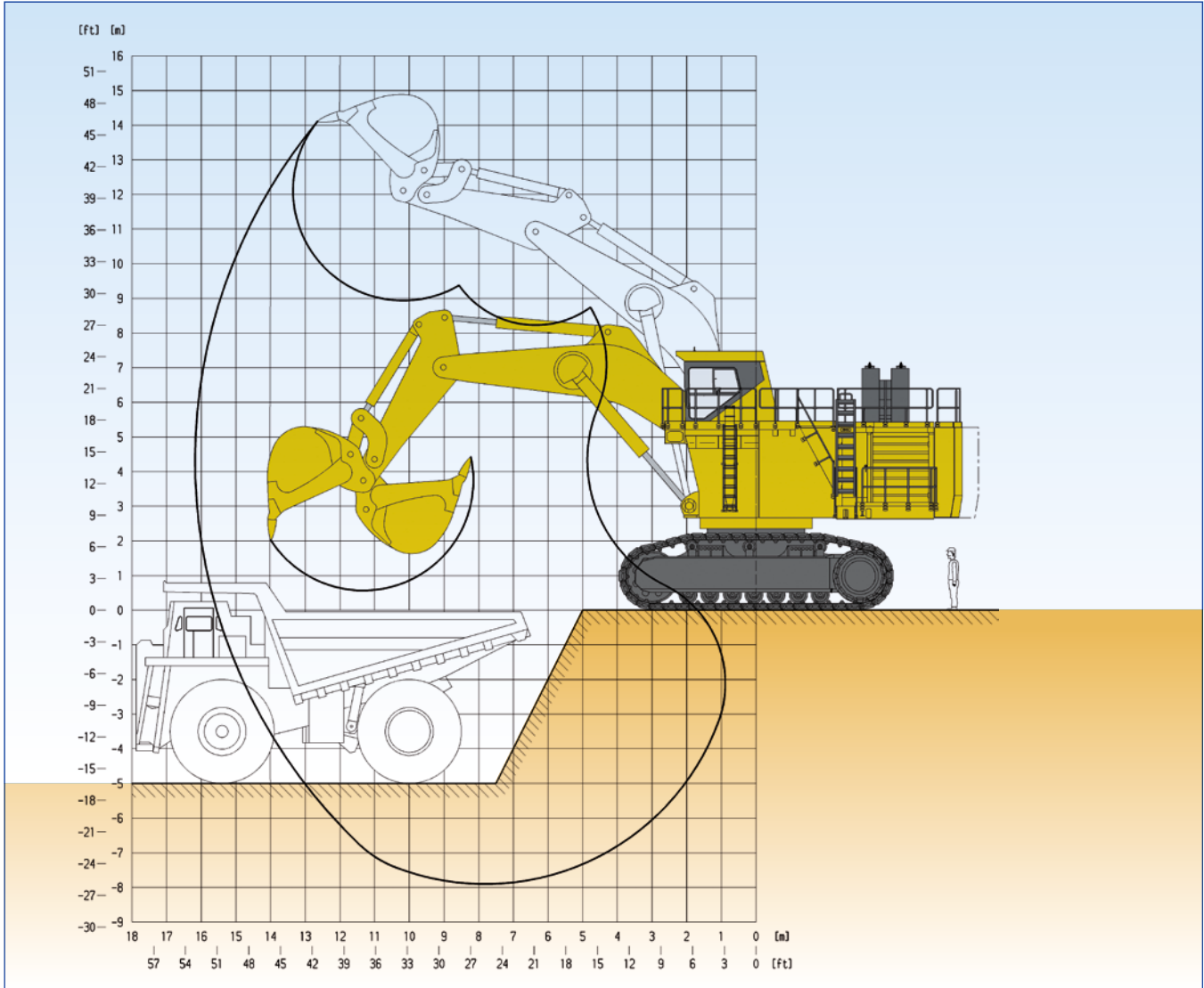

Boom length	8.600 mm	28'3"
Stick length	4.000 mm	13'1"
Break-out force (ISO)	890 kN	200,050 lb
Tear-out force (ISO)	811 kN	182,290 lb

Max. digging height	14.100 mm	46'3"
Max. dumping height	9.000 mm	29'6"
Max. digging depth	7.900 mm	25'11"
Max. digging reach	16.200 mm	53'2"
Max. digging reach at ground level	15.600 mm	51'2"

Bucket Capacity (Heaped 1:1) SAE		Width		Teeth	Wear Package acc. abrasiveness	GET System	Max. Material Density (Loose)	
cum	cuyd	mm	foot/inch	qty			t/cum	lb/cuyd
12,0	15.7	3.045	9'12"	5	heavy	Hensley XS 252 *	2,2	3,700
15,0	19.5	3.260	10'8"	5	standard	Hensley XS 252 *	1,8	3,000
16,5	21.5	3.045	9'12"	5	standard	Hensley XS 252 *	1,6	2,700



FRONT SHOVEL ATTACHMENT

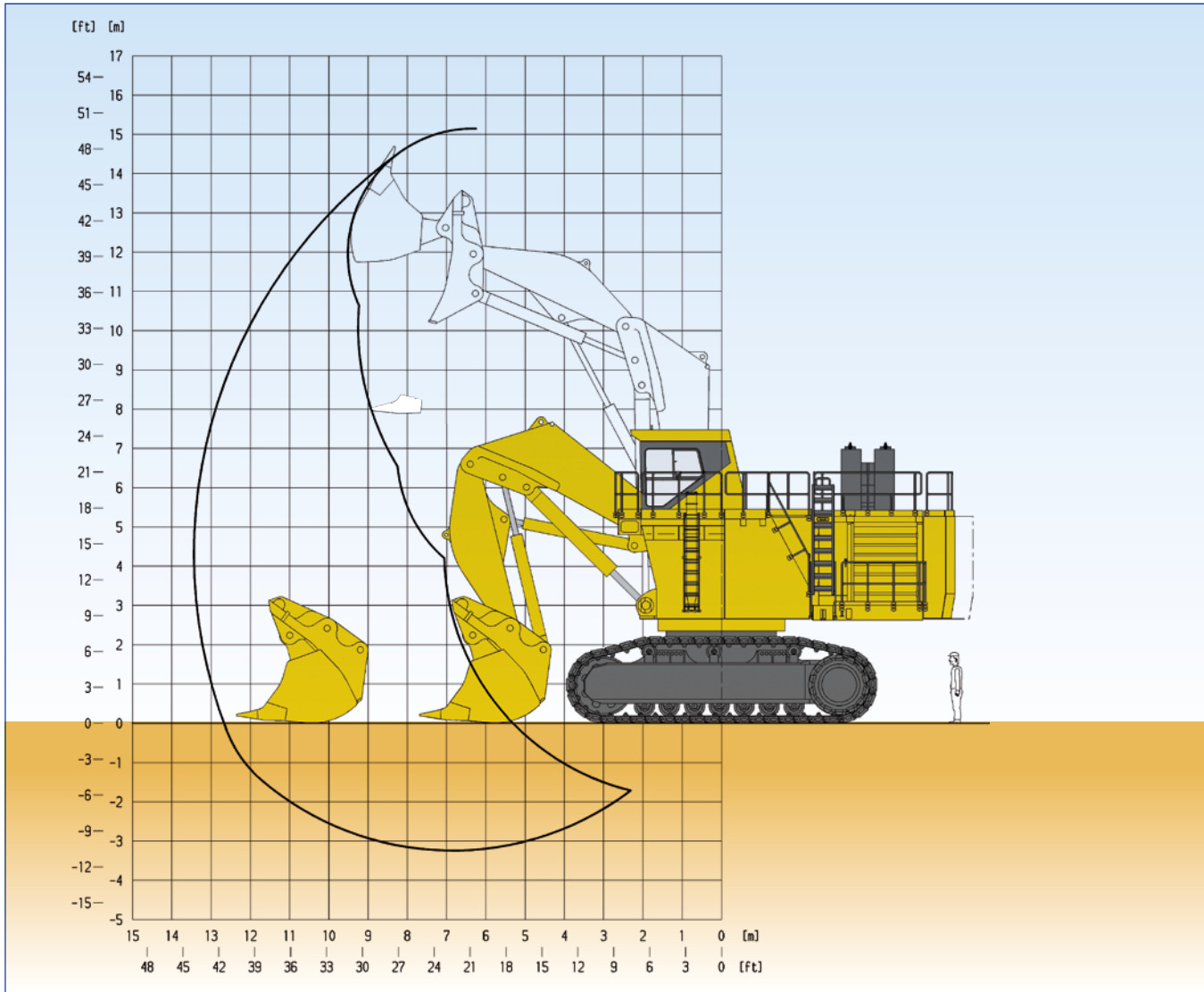

Boom length	6.000 mm	19'8"
Stick length	4.300 mm	14'1"
Break-out force (ISO)	1.066 kN	239,600 lb
Crowd force (ISO)	1.136 kN	255,340 lb

Max. cutting height	15.100 mm	49'6"
Max. dumping height	10.200 mm	33'6"
Max. digging depth	3.300 mm	10'10"
Max. digging reach	13.300 mm	43'8"
Level crowd at ground level	4.700 mm	15'5"
Bucket opening width	2.330 mm	7'8"

Bucket Capacity (Heaped 1:2) SAE		Width		Teeth	Wear Package acc. abrasiveness	GET System	Max. Material Density (Loose)	
cum	cuyd	mm	foot/inch	qty			t/cum	lb/cuyd
12,0	15.7	3.430	11'3"	5	heavy duty	Hensley XS 252 *	2,4	4,000
16,0	21.0	3.790	12'5"	6	standard	Hensley XS 252 *	1,8	3,000

Alternative buckets on request

*other systems on request



STANDARD EQUIPMENT

HYDRAULIC MINING SHOVEL

FRONT SHOVEL ATTACHMENT

- 6,0 m 19'8" boom
- 4,3 m 14'1" stick
- Set of cylinders
- 16 m³ (21 yd³) (SAE 2:1) shovel bucket incl. standard wear package with hammerless GET system

OR

BACKHOE ATTACHMENT

- 8,6 m 28'3" boom
- 4,0 m 13'1" stick
- Set of cylinders
- 15 m³ (19.5 yd³) (SAE 1:1) bucket incl. standard wear package with hammerless GET system

CRAWLER UNDERCARRIAGE

- Heavy-duty shovel type undercarriage
- Centre carbody
- 2 heavy box-type track frames
- 7 bottom rollers and 3 top rollers each side
- 800 mm 31" cast steel track shoes
- Hydraulic track adjustment and parking brake
- Drive gear box protection

SUPERSTRUCTURE

- Main frame mounted over an externally toothed swing circle carries the drive module
- Version 1 - Komatsu SSA12V159 Tier 1 diesel engine
- Version 2 - Komatsu SDA12V159E-2 Tier 2 certificated diesel engine
- Oil and fuel reservoirs
- Hydraulic components
- Counterweight

LIGHTING

- 12 XENON high performance working lights
- Service lights throughout the platform

OPERATOR CAB

- Enclosed steel cab mounted on viscous pads
- FOPS according ISO 3449
- Air-conditioning unit Süttrak
- Full suspension operator seat with belt
- Trainer seat with belt
- Controls ergonomic
- KOMTRAX Plus (Monitoring System)
- Joysticks and controls are hydraulic
- 2 synchronised windshield wash wipers
- AM-FM radio with MP3 ready CD player
- External metal sun blinds on side windows
- Internal roller blinds on all windows

- All windows tinted parsol green
- Walkway in front of cab

LUBRICATION AND SERVICE

- LINCOLN central lubrication for basic machine, attachment and bucket
- LINCOLN automatic pinion lubrication system for swing circle teeth
- WIGGINS service arm carrying fluid receiving connectors for filling of fuel, engine oil and coolant, hydraulic oil and the evacuation of coolant, hydraulic and engine oils

ACCESSORIES INCLUDED

- Acoustic travel alarm
- Hydraulically actuated ground access ladder
- Electric air horn
- Service transfer oil pump
- Sidewalks and stairs are provided with skid-resistant plates
- Guard rails and steps on boom
- Tie off points on boom
- Engine emergency stop at ground level



OPTIONAL EQUIPMENT

ATTACHMENT/BUCKET

- Boom cylinder sliding guard
- Arm cylinder sliding guard
- Bucket cylinder sliding guard (BH)

UNDERCARRIAGE

- 1.000 mm 39" track shoes
- 1.200 mm 47" track shoes

POWER

- Electric drive various voltages
- Cable guide without cable
- Fire suppression system, Ansul (Agent LVS+Powder), diesel drive

COLD WEATHER

- Cold weather package down to -40° C (diesel and electro drive)
- Arctic weather package down to -50° C (diesel and electro drive)
- Hotstart temperature treatment for ambient temperature down to -50° C (diesel and electro drive), external power source not included

SPECIFIC HYDRAULIC OIL

- Biodegradable hydraulic oil

MISCELLANEOUS

- Engine oil management package (Centinel, Reserve & Eliminator systems)
- Additional lighting
- Additional cab heater
- Sound suppression kit
- Special painting



DIMENSIONS

BASIC MACHINE WITH COUNTERWEIGHT

A	800 mm	2'7"	I	2670 mm	8'9"
B	1000 mm	3'3"	J	2610 mm	8'7"
C _A	5640 mm	18'6"	K	6802 mm	22'4"
C _B	5840 mm	19'2"	L	7479 mm	24'6"
D	2210 mm	7'3"	M _A	3740 mm	12'3"
E	935 mm	3'1"	M _B	3010 mm	9'11"
F	3000 mm	9'10"	N	3060 mm	10'1"
G	6000 mm	19'8"	O	6800 mm	22'6"
H	7914 mm	25'12"	P	5950 mm	19'6"
			P _R	6402 mm	20'12"

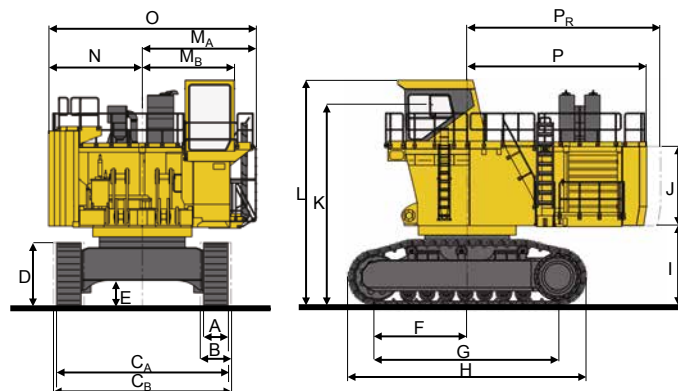

KOMATSU

Komatsu Germany GmbH

Buscherhofstrasse 10, 40599 Duesseldorf, Germany

Phone: +49 (0) 211 71 09-0, Fax: +49 (0) 211 71 58-22

info@komatsu-mining.de, www.komatsu-mining.de



QES0037 03