

KOMATSU®

730E-10

ELECTRIC DRIVE TRUCK



Photos may include optional equipment.

GROSS HORSEPOWER
2,000 HP 1492 kW

NOMINAL GVW
745,328 lb 338075 kg

PAYLOAD
205 ton 186 metric ton

730E-10

WALK-AROUND

PRODUCTIVITY FEATURES

- High performance Komatsu SSDA16V159E-2 engine
- Gross horsepower 1492 kW **2,000 HP**
- 2535 kW **3,400 HP** retarding capability
- Automatic speed control (retard & propel) with automotive style cruise control
- Traction (spin-slide) control
- Komatsu designed application specific body
- Tight turning radius 13.6 m **44' 6"**
- Payload Meter™ IV

RELIABILITY FEATURES

- Frame design for 186 metric ton **205 ton** payload
- Wheel motor design based on proven GEB25 and 788
- Simple and reliable hydraulic system
- Steering and brake accumulators
- Hydraulically actuated dry disc brakes
- Compact inverter
- Solid-state retarding with dual choppers

730E-10



Photos may include optional equipment.

NET HORSEPOWER

1,884 HP 1405 kW

PAYLOAD

205 ton 186 metric ton

OPERATOR ENVIRONMENT

- Ergonomically designed spacious cab with excellent visibility
- Fully adjustable driving position settings
- Four post ROPS/FOPS level 2 cab
- User friendly display with payload information
- Komatsu Hydrair® II suspensions designed for optimum ride comfort
- AM/FM/CD/MP3/USB/weather band radio



EASY MAINTENANCE

- KOMTRAX Plus® 2 allows immediate diagnostics of key engine, chassis, and drive system components
- Automatic lubrication system
- In-tank fast fuel and DEF fill system
- Flange type rims

ENVIRONMENTALLY FRIENDLY

- Komatsu SSDA16V159E-2 fuel efficient engine
- Komatsu SSDA16V159E-3 fuel efficient engine is compliant with U.S. E.P.A. Tier 4 emissions regulations

PRODUCTIVITY FEATURES

Komatsu High Horsepower Engine

Komatsu's 2,000 HP engine will operate in most of today's mining applications without experiencing power derate. Fuel efficiency is maximized due to optimized air handling. Standard features include:

- A standard pre-lube system designed to reduce start-up wear and increase overhaul life.
- CENSE™ on-board monitoring of engine performance for each cylinder.
- ELIMINATOR® filtration system reduces oil and filter changes by one-third.



IGBT AC Electric Drive System

The GTA49 traction alternator coupled with GEB35 wheelmotors and Invertex® II AC control system provides reliable performance and easy maintenance. Invertex® II offers independent control of the rear wheelmotors, which in turn provides outstanding traction-ability during wet and slippery conditions, thus improving tire wear and operator confidence.

The air cooled Insulated Gate Bipolar Transistor (IGBT) inverter system technology provides the highest available reliability. The IGBT inverter is more compact and much simpler than the design of its predecessor, the Gate Turn Off (GTO) inverter, which improves serviceability and routine maintenance.

Electric Dynamic Retarder

The 2535 kW **3,400 HP** retarding system provides state of the art braking capacity for navigating today's mining applications which contain steep continuous descents and sharp switch-backs. Continuous retarding capacity enhances the productivity of the vehicle operator, while eliminating the need for excessive mechanical braking effort.



Traction (Spin-Slide) Control

During slippery conditions, the 730E-10 wheel traction control technology detects and corrects wheel spin or slide events. Traction control operates automatically and independently of the service brakes. During propulsion, “wheel spin control” reduces non-productive wheel spin in low traction conditions. During retarding, “wheel slide control” helps prevent wheel lockup and subsequent sliding.

Cruise Control

Cruise control both in propulsion and retarding, allows the operator to concentrate on steering and situational awareness while maintaining a constant speed. A set speed indicator provides confirmation the truck speed matches the desired speed selected by the operator with simple automotive-style controls.

Komatsu Designed Application Specific Body

Utilizing the required Body Worksheet (BW) process, Komatsu ensures that each body is designed to meet the requirements for each specific application while carrying its rated payload. Komatsu works with each customer to understand all of the material properties at a mine site and to identify the appropriate liner package.

Komatsu offers a standard all-welded steel, flat floor body with a full canopy and horizontal bolsters. This body includes a driver side eyebrow, body up sling, and rubber mounts on the frame.

- Standard Body SAE Heaped 2:1: 133 m³ **174 yd³**
- Standard Komatsu Body Weight: 28366 kg **62,535 lbs**



PRODUCTIVITY FEATURES



Tight Turning Radius

By using double acting hydraulic steering cylinders with a six-point articulation linkage, the power steering system provides steering control with minimal operator effort. The turning radius is 13.6 m 44' 6", which provides excellent maneuverability for tight loading and dumping conditions. The steering accumulators comply with ISO-5010 standards.

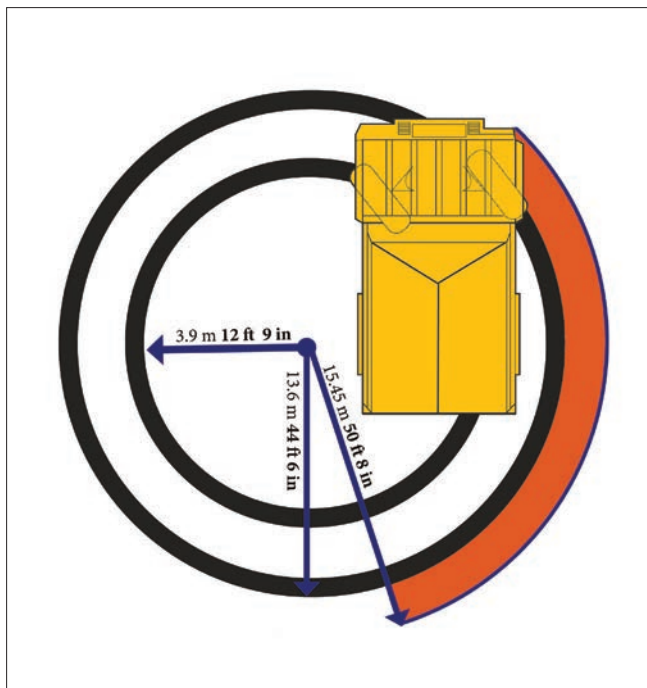

Payload Meter™ IV (PLM™ IV)

PLM™ IV is an electronic system that monitors and records payload information for Komatsu's off-highway mining trucks. The accurate and reliable payload measurement system is designed to help optimize payload, maximize productivity and reduce the life cycle cost of the machine. PLM™ IV tracks and records the following key production parameters:

- Payload
- Empty Carry-Back
- Operator Identification
- Haul Cycle, Loading, Dumping Time and Date
- Distance Traveled (Loaded and Empty)
- Cycle Time Information
- Maximum Speeds (Loaded and Empty)
- TMPH Estimate for Front and Rear Tires
- Average Speed (Loaded and Empty)

Hydrair® II Hydropneumatic Suspension

Hydrair® II is a suspension system that utilizes four nitrogen-over-oil cylinders. This suspension system is designed to maximize machine productivity by providing the operator with a smooth and comfortable ride. By absorbing shocks to the chassis during operation, Hydrair® II contributes to the durability of the machine's frame and components.



OPERATOR ENVIRONMENT

Operator Seat

Komatsu recognizes that operator comfort is a key to productivity in today's mining environment. The five-way adjustable operator seat and the tilt-telescopic steering column provides an optimum driving posture for increased operator comfort and control over the machine. The air suspension seat absorbs vibrations transmitted from the machine, reducing operator fatigue. A 51 mm **2 in** wide, blaze orange, three-point seat belt is provided as standard equipment.

Built-in ROPS and FOPS Structure

These structures conform to ISO standards 3471 and 3449.

Ergonomically Designed Cab

The Komatsu 730E-10 cab design provides a comfortable and productive environment to meet today's mining demands. The cab includes tinted safety glass windows, heating and air conditioning, acoustical insulation, double sealed doors and filtered and pressurized air to reduce dust.

User Friendly Display

The 730E-10 features a new operator friendly dash configuration which includes lighted gauges, switches and information panel. This allows the operator to see the status of the machine during operation and informs them of any faults. An instructive message will appear after any fault is detected on the machine.



Photo may include optional equipment.

TIER 4

730E-10

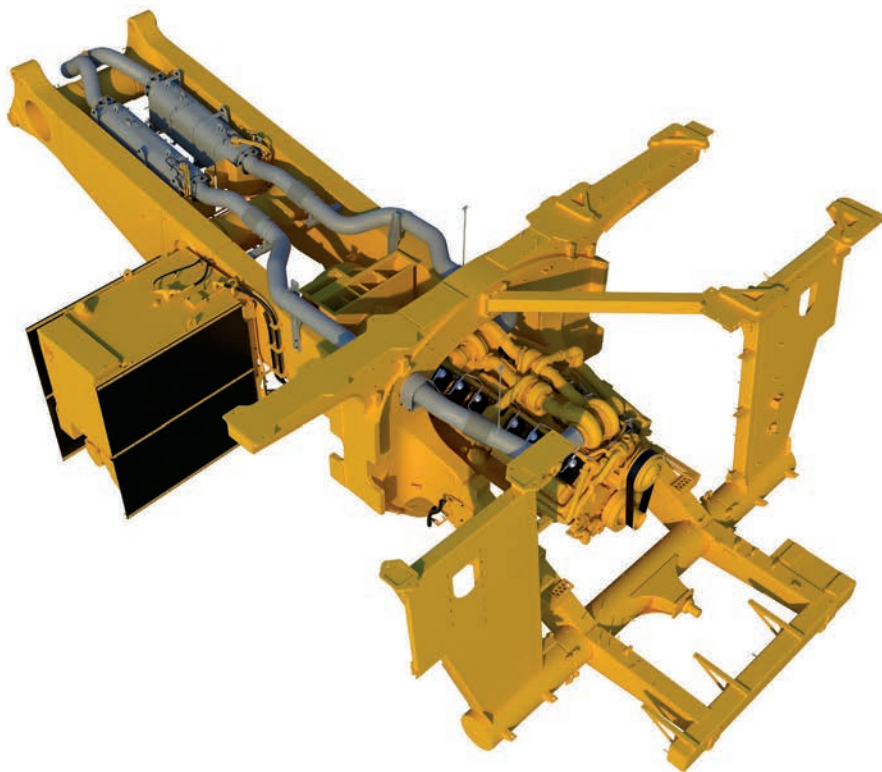

Evolutionary, not Revolutionary Design

Komatsu's Tier 4 solution begins with a base engine which is very similar to the previous Tier 2 platform. In keeping the basic operation of the engine the same, the prior platform's durability is continued. Utilizing High Pressure Common Rail fuel delivery ensures atomization of the fuel/air mixture to a level which reduces particulate matter, meeting U.S. EPA Tier 4 standards.

Komatsu After-treatment

Removal of NOx is accomplished by treating the exhaust through Selective Catalytic Reduction (SCR). The introduction of Diesel Exhaust Fluid (DEF) into the SCR canister generates a chemical reaction which breaks down the oxides of nitrogen into oxygen and nitrogen, both non-pollutants. Internal cleaning of the SCR is performed through an automatic process.



RELIABILITY FEATURES

Structurally Enhanced Frame Design

By using advanced computer-aided design, finite element analysis, and full-scale dynamic testing, the frame has been designed to carry 186 metric tons **205 short tons** and provides the high structural reliability Komatsu is known for.

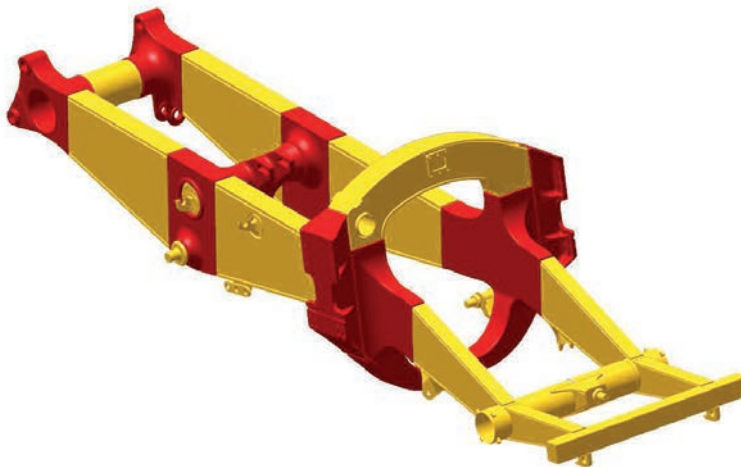

Castings Used in High Stress Areas

To increase frame reliability, steel castings have been incorporated at key frame pivot points and critical load bearing portions of the structure. This includes the rear body pivot and horsecollar sections.

Simple and Reliable Hydraulic System

The hydraulic system is a proven and reliable design with fewer parts than most other OEMs. The system utilizes a single tank, providing one common source of fluid for steering, braking, and hoisting. In-line, replaceable filtration elements provide protection from hydraulic system contamination, making the system easier to service.

To keep downtime to a minimum, Komatsu developed a sub-frame pump module that can be removed and replaced as a single unit. This reduces change-out time and allows easy access to the hydraulic pump module.

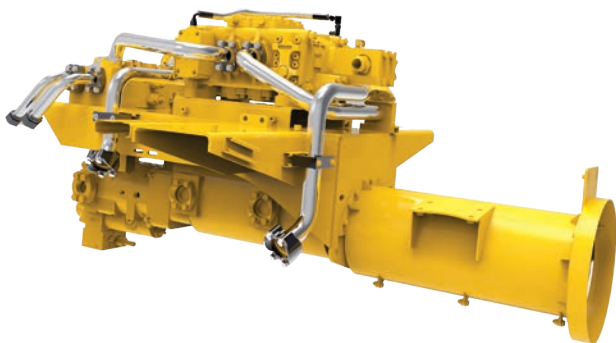

Proven Wheel Motor Design

The GEB35 wheel motor builds on the success of its predecessor. Held to the highest standards, the transmission was subjected to extensive testing and quality confirmation. A full scale controlled durability and field test was conducted at Komatsu's Proving Grounds during development to confirm design quality prior to production. By using planetary design, extensive machining is not required during a standard rebuild.

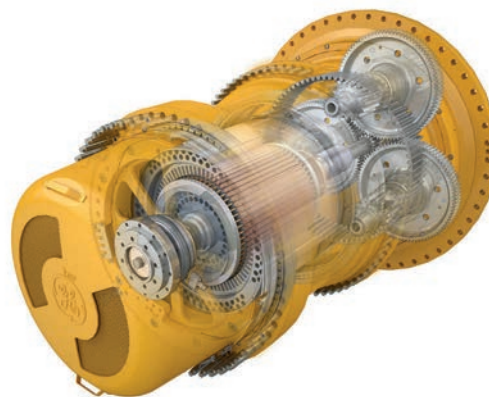

EASY MAINTENANCE

Access, Service and Convenience

Located on the front left bumper adjacent to the main entry to the machine, Komatsu installs many service and convenience items. This central location simplifies maintenance events, reducing the time the truck is out of service for routine upkeep.

1. Power, starter and drive system lockout (lock-out/tag-out capable switches)
2. Emergency engine shut-down
3. Fluid service center (coolant, engine oil, hydraulic oil, grease fill)
4. Hydraulic step up/down light switch (Hydraulic stairs are optional)

KOMTRAX Plus® 2

As part of a complete service and support program, Komatsu equips every mining and quarry sized machine with KOMTRAX Plus® 2. By using a satellite-based communication system, KOMTRAX Plus® 2 offers a new vision of monitoring your valuable assets. By providing insight to critical operating metrics the user can manage increased availability, lower owning and operating costs and maximize fuel efficiency.

The information available through KOMTRAX Plus® 2 allows service personnel to review faults and trends, improve the quality of the troubleshooting process and reduce unscheduled machine downtime.



ADDITIONAL FEATURES

Lower Environmental Impact

Less Fluids than Mechanical Drives

Komatsu electric drive trucks contain up to 57% less hydraulic fluid compared to similar class mechanical drive trucks, creating a lower environmental impact and makes fluid replacement simpler, quicker and more economical.

U.S. EPA Compliant

The Komatsu SSDA16V159E-3 engine is compliant with the U.S. EPA Tier 4 emissions regulations.

Reduced Fuel Consumption

The engine and drive system are specifically tuned together, providing efficient power usage and minimizing fuel consumption.

Komatsu Loading Policy for Mining Trucks

In normal loading operations, variations in payloads occur. The loading policy identifies the guidelines and limitations for the loading of those Komatsu Mining Truck models specified.

Definitions:

- **Rated GVW** (Gross Vehicle Weight) includes the chassis, body, tires, accessories (including local options), lube, fuel, operator, payload and any excess material build-up.
- **Rated Payload** is the resultant difference of Rated GVW minus EVW.
- **Overload** refers to any payload amount in excess of the Rated Payload.
- **Never to exceed GVW** is the maximum allow able GVW under the guidelines of this Policy.

Actual payloads greater than the Rated Payload are allowable, but shall not result in a GVW that is greater than the Never to Exceed GVW.

No single payload that results in a **GVW** in excess of the Never to Exceed GVW is allowed under any circumstances.

The mean of all payloads for a rolling 30-day period shall not exceed the Rated Payload.

Truck Model	730E-10	
Specification	lb	kg
Rated GVW	745,328	338,075
Standard Tire Size	37.00R57	
Rated / Nominal Payload	410,000	185,973
Never To Exceed GVW	827,328	375,270

SPECIFICATIONS



ENGINE

Make and model.....	Komatsu SSDA16V159E-2
Fuel	Diesel
Number of cylinders	16
Operating cycle	4 cycle
Gross horsepower*.....	1492 kW 2,000 HP @ 1900 rpm
Net flywheel power**.....	1405 kW 1,884 HP @ 1900 rpm
Weight (wet)	6164 kg 13,590 lb

* Optional Tier 4 emissions compliant engine SSDA16V159E-3 available for North American Market

* Gross horsepower is the output of the engine as installed in this machine, at governed rpm and with engine manufacturer's approved fuel setting. Accessory losses included are water pump, fuel pump and oil pump.

**Net flywheel power is the rated power at the engine flywheel minus the average accessory losses. Accessories include fan and charging alternator. Rating(s) represent net engine performance in accordance with SAE J1349 conditions.



ELECTRIC DRIVE

AC/DC CURRENT	
Alternator	GTA-49
Dual impeller in-line blower	371 m ³ /min 13,100 cfm
Control	Invertex II
Motorized wheels*	GEB35 Traction Motors
Ratio.....	30.8:1
Speed (maximum)	64.5 km/h 40 mph

* Wheel motor application depends upon gross vehicle weight, haul road grade, haul road length, rolling resistance and other parameters. Komatsu and G.E. must analyze each job condition to assure proper application.



TIRES AND RIMS

Rock service, tubeless, radial tires	
Standard tire*	37.00R57
Optional tires	40.00R57
Flange mount rim	
686 mm x 1448 mm x 152 mm 27" x 57" x 6" rim assembly.	
Rims rated at 758 kPa 110 psi cold inflation pressure.	
Optional rim	
736 mm x 1448 mm x 152 mm 29" x 57" x 6" rim assembly.	
Standard tire weight (6).....	23016 kg 50,7500 lb

* Tires should meet application requirements for tkph/tmph, tread, compound, inflation pressure, ply rating or equivalent, etc.



CAB

Advanced Operator Environment with integral 4-post ROPS/FOPS Level 2 structure (ISO 3449), adjustable air suspension seat w/ lumbar support and arm rests, full-size passenger seat, maximum R-value insulation, tilt and telescoping steering column, electric windshield wipers w/washer, tinted safety glass, power windows, Payload Meter™ IV, 55,000 Btu/hr heater and defroster, 21,600 Btu/hr air conditioning (HFC - 134A refrigerant).



SUSPENSION

Variable rate hydropneumatic with integral rebound control	
Max. front stroke	312.6 mm 12.31"
Max. rear stroke	279.1 mm 10.99"
Max. rear axle oscillation	±5.3°



FRAME

Advanced technology, full butt-welded box sectional ladder-type frame with integral ROPS supports, integral front bumper, rear tubular cross members, steel castings at all critical stress transition zones, rugged continuous horsecollar.

Plate material.....	482.6 mPa 70,000 psi
	tensile strength steel
Casting material.....	620.5 mPa 90,000 psi
	tensile strength steel
Rail width.....	280 mm 11.02"
Rail depth (minimum)	797 mm 31.38"
Top and bottom plate thickness.....	32 mm 1.26"
Side plate thickness.....	19 mm 0.75"
Drive axle mounting	Pin and spherical bushing
Drive axle alignment.....	Swing link between frame and axle



BODY

All-welded steel flat floor body with horizontal bolsters and full canopy. Eyebrow, rear wheel rock ejectors, body up sling and rubber mounts on frame are standard.

Floor sheet	16 mm 0.63" Outer 19 mm 0.75" Center
	1379 MPa 200,000 psi tensile strength steel
Front sheet	10 mm 0.39"
	1379 MPa 200,000 psi tensile strength steel
Side sheet	8 mm 0.31"
	1379 MPa 200,000 psi tensile strength steel
Canopy sheet	6 mm 0.24"
	690 MPa 100,000 psi tensile strength steel
SAE heaped 2:1.....	111 m ³ 145 yd³
Standard Komatsu body weight	28169 kg 62,100 lb



BRAKING SYSTEM

System meets ISO3450/2011 standards.
Service brakes: all-hydraulic actuated.

Front	Wheel speed disc
	Three calipers on a 1168.4 mm 46.08" O.D. disc
Rear	Dual disc armature speed
	Two 635 mm 25.00" O.D. discs per side
	One caliper per disc
Traction system	Wheel spin-slide control
Front service apply pressure	17237 kPa 2,500 psi
Rear service apply pressure.....	7722 kPa 1,120 psi
Secondary Braking System.....	Automatically applied prior to hydraulic system pressure dropping below an acceptable level. System meets ISO secondary stopping requirements.
Wheel brake locks.....	Switch-activated
Parking brakes	Spring-applied, hydraulically released, with speed application protection.
	Rated to hold on ±15% grade at maximum GVW.
Electric dynamic retarder	2535 kW 3,400 hp



COOLING SYSTEM

L&M radiator assembly, split-flow, with deaerator-type top tank.	
Radiator frontal area	4.65 m ² 50.1 ft²

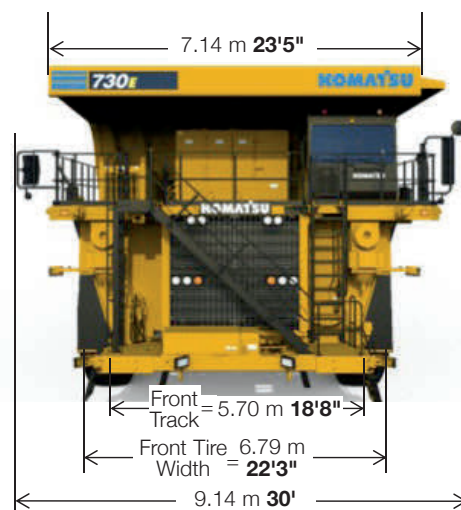
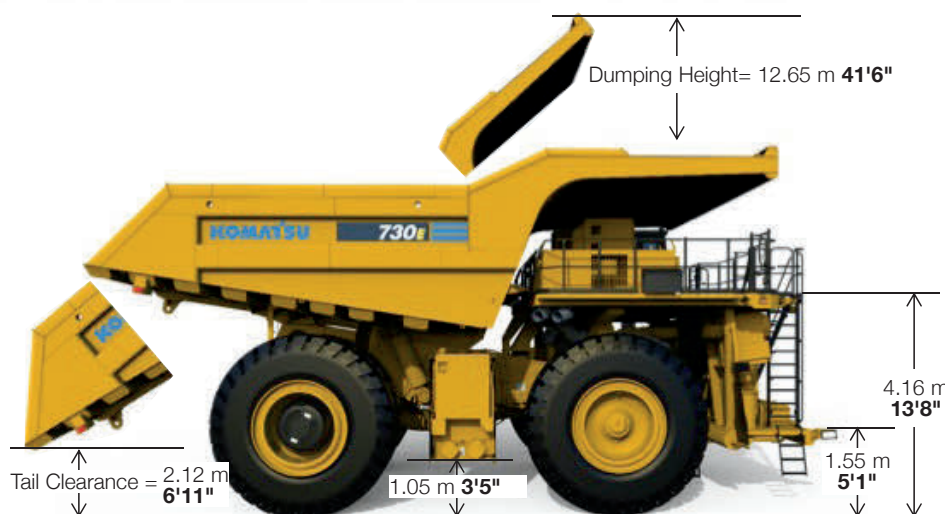
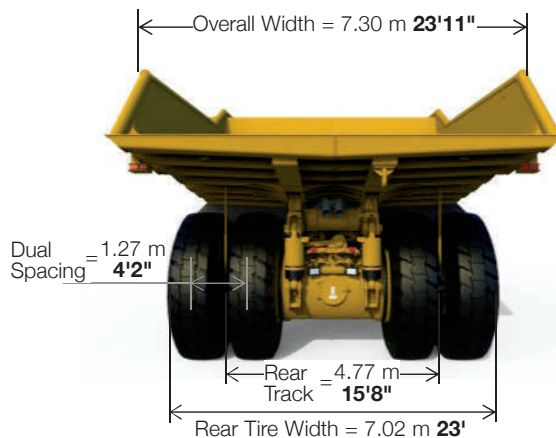
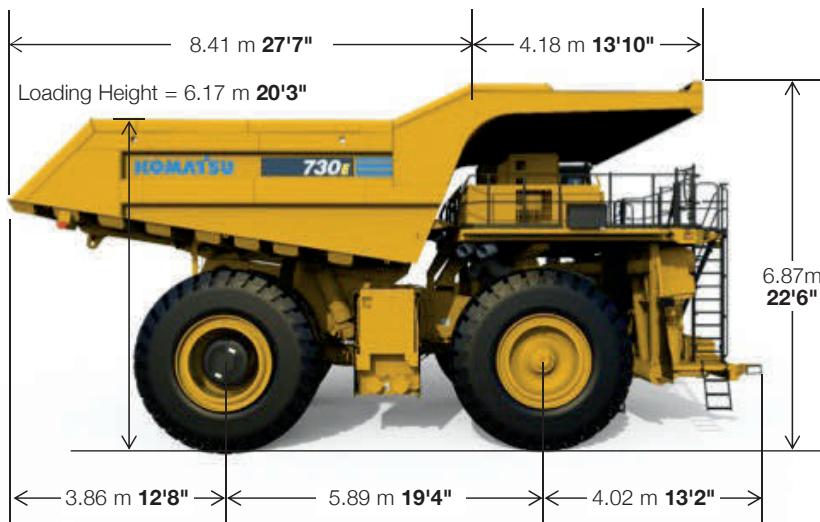

HYDRAULIC SYSTEM

Steering..... Accumulator assisted with twin double acting cylinders provide constant rate steering.
 Secondary steering automatically supplied by accumulator.
 Turning circle diameter (SAE)..... 27.2 m 89'
 Reservoir 507 L **134 U.S. gal**
 Filtration..... In-line replaceable elements
 Suction Single, full-flow, 100 mesh
 Hoist and steering Dual, in-line, high pressure
 Brake component cabinet..... Above deck, easily accessible with diagnostic test connections
 Hoist Two 3-stage dual acting outboard cylinders, internal cushion valve, over-center dampening
 Hoist times
 Power-up loaded 21.4 sec
 Power-down 10.5 sec
 Float-down empty 14.0 sec
 Pumps..... Two pumps, single package, end of alternator
 Hoist and brake cooling Tandem gear pump with output of 666 lpm **176 gpm** at 1900 rpm and 17236 kPa **2,500 psi**
 Steering and brake Pressure-compensating piston pump with output of 254 lpm **67 gpm** at 1900 rpm and 19132 kPa **2,775 psi**
 System relief pressures
 Hoist 17237 kPa **2,500 psi**
 Steering and brake 27579 kPa **4,000 psi**

Body	Capacity	Loading Height*
	2:1 Heap	
Standard	133 m ³ 174 yd³	6.32 m 21'

*Exact load height may vary due to tire make, type, and inflation pressure.



ELECTRICAL SYSTEM

4 x 8D 1450 CCA, 12 volt, in series/parallel, 220 ampere-hour batteries, bumper-mounted with disconnect switch.
 Lighting 24 volt
 Cranking motors Two/24 volt



SERVICE REFILL CAPACITIES

Cooling System	441 L	117 U.S. gal
Crankcase*	223 L	59 U.S. gal
Hydraulic system	796 L	210 U.S. gal
Motor gear box (each)	38 L	10 U.S. gal
Fuel tank	3146 L	831 U.S. gal
DEF tank	288 L	76 U.S. gal

*Includes lube oil filters

SPECIFICATIONS

Truck Performance Graph

730E-10

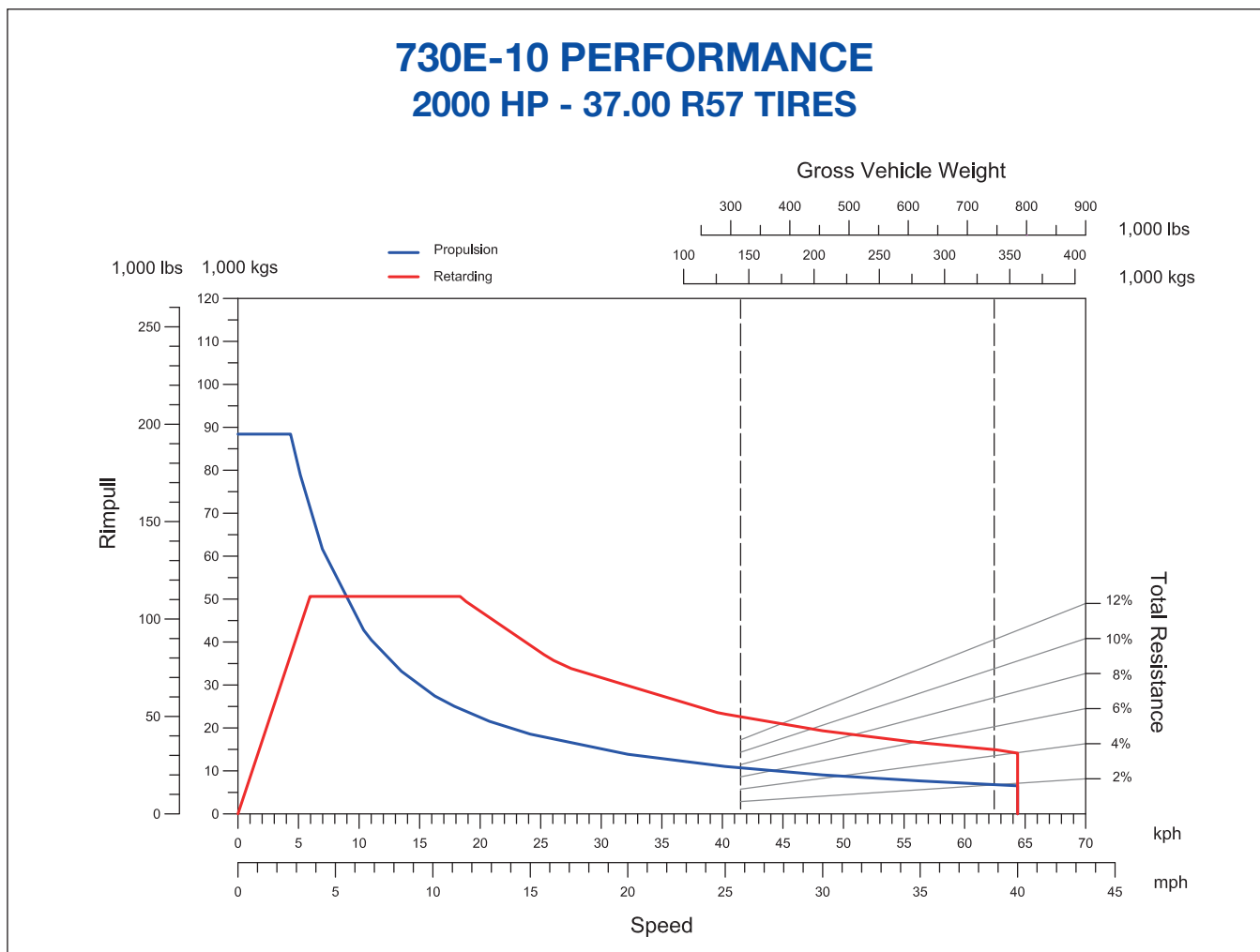

Empty Vehicle Weight (Standard overseas truck)

Front Axle Distribution	71,114 kg	156,779 lbs	49.4%
Rear Axle Distribution	72,834 kg	160,571 lbs	50.6%
Total EVW	143,948 kg	317,350 lbs	
Optional Allowance	8,154 kg	17,978 lbs	

Gross Vehicle Weight

Front Axle Distribution	111,565 kg	245,958 lbs	33%
Rear Axle Distribution	226,510 kg	499,370 lbs	67%
Nominal GVW	338,075 kg	745,328 lbs	

Payload

Nominal Payload	205 short tons	410,000 lbs
	185,973 kg	186 metric tons

Nominal payload is defined by Komatsu America Corp.'s payload policy documentation. In general, the nominal payload must be adjusted for the specific vehicle configuration and site application. The figures above are provided for basic product description purposes.

Please contact your Komatsu distributor for specific application requirements.





STANDARD EQUIPMENT

- Air cleaners, Donaldson® w/evacuators
- Alternator
- Auto lubrication system w/ground level fill & level indicator
- Back up alarm
- Batteries—4 x 8D (1450 CCA's)
- Battery charging cable and socket
- Body impact plate
- Brakes: dry front & rear
 - Front - wheel speed disc
 - Rear - dual disc armature speed
- Cruise speed control
- Deck guard rails
- Electric start
- Fast-fill fuel system (in tank and left side remote)
- Filters, high pressure hydraulic
- Fuel tank sight gauge (1)
- Ground level radiator fill
- L&M Radiator
- Mud flaps
- Muffled exhaust—deck-mounted
- Power supply, 24 volt and 12 volt DC
- Quick disconnects (hoist and steering)
- Radiator sight gauge
- Removable power module unit (radiator, engine, alternator, blower)
- Reverse retarding
- Service center—LH
- Thermostatic fan clutch

OPERATOR ENVIRONMENT & CONTROL:

- All hydraulic service brakes w/auto apply
- Battery disconnect switch
- Brake lock and drive system interlock
- Circuit breakers, 24 volt
- Dedicated auxiliary circuits in operator cab (ladder lights, 2-way radios, fire suppression power)

- Diagonal staircase across grille (L to R) w/ tread
- Dimpled surface on walkways
- Dynamic retarding with continuous rated element grids
- Engine access guard rail
- Engine shutdown at ground level
- Hoist propulsion interlock
- Horns (electric—front and back-up)
- Hydraulic tank ladder
- Integral ROPS/FOPS Level 2 cab
- Isolation mounted cab
- Maintenance and power lockout
- Parking brakes with warning light & speed application protection
- Power steering w/auto secondary steering
- Pump driveline protector
- Radiator fan guard
- RH & LH multi-cambered convex mirrors
- Seat belts
 - Operator 3-point blaze orange 76 mm 3" retractable
 - Passenger lap 76 mm 3" retractable

STANDARD HIGH VISIBILITY DELUXE CAB:

- AC drive interface display
- Air conditioner HFC-134A
- AM/FM radio with CD, USB & MP3
- Dome light
- Electronic Dash & Status Panel
 - Body up
 - Engine oil temperature (high)
 - Parking brake
 - Propulsion system not ready
 - No DC link voltage
 - No propel
 - Service brake applied
 - Wheel brake lock applied
 - Maintenance monitor
- Engine hourmeter, oil pressure gauge, coolant temperature gauge, hydraulic oil temperature gauge
- Engine shutdown w/ "Smart Timer" delay

- Floor mat (double barrier)
- Fuel gauge in cab
- Fuel low level light and buzzer
- Gauges (w/backlight)
- Headlight switch
- Heater and defroster (heavy-duty)
- Heater switch
- High beam selector and indicator
- Horn switch (center of steering wheel)
- Indicator lights (blue)
 - Engine service
 - Komtrax Plus® snapshot (IM)
- Komatsu Payload Meter™ IV
- Komtrax Plus® 2
- Operator seat, adjustable w/air suspension, lumbar support and arm rests
- Panel lighting (adjustable)
- Passenger seat, mechanical suspension
- Power windows
- Pressurized cab air system w/fan on
- Single brake/retarder pedal
- Sunvisor (adjustable)
- Tilt & telescoping steering column
- Voltmeter (battery output)
- Windshield (tinted safety glass)
- Windshield wiper (dual) and washer (electric)

LIGHTING:

- Back-up lights—rear mount (2) LED
- Back-up lights—R and L-deck mount (2) LED
- Brake and retard lights on top of cab
- Clearance lights (LED)
- Dynamic retarding, rear (2) (LED)
- Engine compartment service lights
- Fog lights (2) halogen
- Headlights (8) halogen
- Manual back-up light, switch and indicator
- Payload lights R and L (LED)
- Stairway lights
- Stop & tail lights (2) (LED)
- Turn signals (LED)



OPTIONAL EQUIPMENT

Note: Optional equipment may change operating weight.

- Amber Beacon Light
- Auxiliary hydraulic system
- Body Liners*
- Body up sling
- Bumper mounted headlights
- Double Wall Exhaust Tubes
- Engine Access Platform-LH
- Extended canopy
- Fire extinguisher 9 kg **20 lb**
- Heated body

- Hot start engine coolant (220V 2-2500W)
- Hot start engine oil (220V 2-500W)
- Hot start hydraulic oil
- Komatsu Smart Rims
- Komvision All-Around Monitoring System
- SRI 3 point seat
- Komatsu Retractable Ladder System
- LED headlights
- Mudflaps on hydraulic tank & fuel tank
- PLM™ IV scoreboards

- Premium Operator Seat
- Rock Ejectors
- Service center—RH
- Shutters (radiator)
- Special language decals
- Suspensions, cold weather
- Wiggins Quick Fluid Fill & Engine Oil Evacuation System

*Available factory installed or non-installed. All other options and accessories listed are available factory installed only.

AESS941-01

©2019 Komatsu America Corp.

Printed in USA

AD08(POD)OTP

08/19 (EV-1)

KOMATSU®

Note: All comparisons and claims of improved performance made herein are made with respect to the prior Komatsu model unless otherwise specifically stated.

www.komatsuamerica.com

Komatsu America Corp. is an authorized licensee of Komatsu Ltd. Materials and specifications are subject to change without notice.

KOMATSU®, Komatsu Care® KOMTRAX® and KOMTRAX Plus® 2 are registered trademarks of Komatsu Ltd.

All other trademarks and service marks used herein are the property of Komatsu Ltd., Komatsu America Corp. or their respective owners or licensees.

730E-10