

# TECHNICAL DATA

TANDEM ROLLERS

BW 135 AD-5, BW 138 AD-5

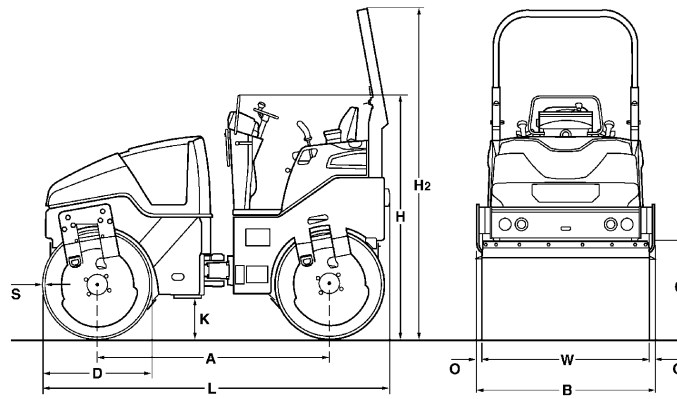



**Dimensions in mm**

	<b>A</b>	<b>B</b>	<b>C</b>	<b>D</b>	<b>H</b>	<b>H2</b>	<b>K</b>	<b>L</b>	<b>O</b>	<b>S</b>	<b>W</b>
<b>BW 135 AD-5</b>	1900	1390	700	900	1895	2703	340	2840	44	16	1300
<b>BW 138 AD-5</b>	1900	1468	700	900	1895	2703	340	2840	44	18	1380

**Shipping dimensions in m3**

**BW 135 AD-5**  
**BW 138 AD-5**

**without ROPS**

7,481  
 7,900

**with ROPS**

10,670  
 11,269

<b>Machine type</b>	<b>Compaction output (m3/h) at recommended soil layer thicknesses</b>		
	<b>Gravel, sand</b>	<b>Mixed soil</b>	<b>Silt, clay</b>
BW 135 AD-5	90-180	70-140	40-80
BW 138 AD-5	100-200	80-160	40-80

<b>Machine type</b>	<b>Compaction output (t/h) at different asphalt layer thicknesses</b>		
	<b>2-4 cm</b>	<b>6-8 cm</b>	<b>10-14 cm</b>
BW 135 AD-5	30-55	50-85	75-130
BW 138 AD-5	30-55	50-90	75-135

## Technical Data

## BOMAG BW 135 AD-5

## BOMAG BW 138 AD-5

### Weights

Operating weight w. ROPS CECE .....	kg	4.000	4.400
Average static linear load CECE .....	kg/cm	15,4	15,9
Grossweight .....	kg	4.200	4.600

### Dimensions

Working width .....	mm	1.300	1.380
Track radius, inner .....	mm	2.665	2.616

### Driving Characteristics

Speed .....	km/h	0- 10,0	0- 10,0
Working speed with vibration .....	km/h	0- 10,0	0- 10,0
Max. gradeability without/with vibr. ....	%	40/30	40/30

### Drive

Engine manufacturer .....		Kubota	Kubota
Type .....		V 2203	V 2203
Emission stage .....		Stage IIIa / TIER4i	Stage IIIa / TIER4i
Cooling .....		water	water
Number of cylinders .....		4	4
Performance ISO 14396 .....	kW	33,3	33,3
Performance SAE J 1995 .....	hp	44,7	44,7
Speed .....	min-1		2.600
Speed adjustment 1 .....	min-1	2.140	2.770
Speed adjustment 2 .....	min-1	2.770	2.140
Electric equipment .....	V	12	12
Driven drum .....		front + rear	front + rear

### Brakes

Service brake .....		hydrost.	hydrost.
Parking brake .....		hydromec.	hydromec.

### Steering

Steering system .....		oscil.artic.	oscil.artic.
Steering method .....		hydrost.	hydrost.
Steering / oscillating angle +/- .....	grad	32/10	32/10
Crab walk .....		0- 50	0- 50

### Exciter system

Vibrating drum .....		front + rear	front + rear
Drive system .....		hydrost.	hydrost.
Frequency .....	Hz	50/56	50/56
Amplitude .....	mm	0,50	0,50
Centrifugal force .....	kN	39/48	45/57

### Sprinkler System

Type of sprinkling .....		pressure	pressure
--------------------------	--	----------	----------

### Capacities

Fuel .....	l	55,0	55,0
Water .....	l	310,0	310,0

Technical modifications reserved. Machines may be shown with options.

### Standard Equipment

- Hydrostatic travel and vibration drive
- 2 scrapers per drum, spring loaded and tiltable
- Pressure sprinkler system with interval switch
- Multi function travel lever
- Multi-function display incl. operating hour meter
- Water level
- Electronic fuel gauge
- Emergency STOP
- Individual control, vibration
- Intelligent Vibration Control (IVC)
- Integrated stowage compartment
- Sliding seat incl. double travel lever
- Seat contact switch
- 12V socket
- Working lights front and rear
- Vandalism protection
- Lockable engine hood made of composite material
- Lashing eyes, galvanized
- Single point lifting device
- Back-up alarm

### Optional Equipment

- \*Foldable ROPS incl. seat belt
- Sun roof, rigid
- Sun roof, foldable with ROPS
- Weather protection for sun roof
- Weather protection cabin
- Seat heating
- ECONOMIZER with asphalt temperature display
- Temperature display
- BOMAG TELEMATIC
- Indicator and hazard lights
- Rotary beacon
- Optional lighting on ROPS
- Lighting for drum edge
- Battery disconnect switch
- Environmentally compliant hydraulic oil
- Theft protection
- Edge cutter-right/left
- Gravel scatterer
- Hydraulically adjustable crabwalk (50mm)
- Pointer
- Special painting
- Backup warning buzzer with broadband technology
- Flow divider
- 2. Amplitude:0,2mm

\* Standard delivery with CE conformity  
(valid within European Union)

