

KOMATSU®

WA500-8

*Tier 4 Final Engine
Yard Loader*

WHEEL LOADER



Photos may include optional equipment.

NET HORSEPOWER

353 HP @ 1900 rpm
263 kW @ 1900 rpm

OPERATING WEIGHT

80,647 – 81,020 lb
36,581 – 36,750 kg

BUCKET CAPACITY

8.2 – 9.8 yd³
6.3 – 7.5 m³

WA500

Yard Loader

YARD LOADER WALK-AROUND

Yard Loader Specific Items

Large capacity bucket and bucket cylinder provide increased productivity in multiple applications such as truck loading, stock piling and charging hoppers.

Low profile, wider tires provide increased ground contact and enhanced stability.

Additional counterweight allows for increased bucket capacity and improved stability.

Brake cooling system, front and rear maximizes brake life in extended carry and high speed applications.



NET HORSEPOWER

353 HP @ 1900 rpm
263 kW @ 1900 rpm

OPERATING WEIGHT

80,647 – 81,020 lb
36,581 – 36,750 kg

BUCKET CAPACITY

8.2 – 9.8 yd³
6.3 – 7.5 m³

WA500-8 Yard Loader



PERFORMANCE, DURABILITY AND FUEL ECONOMY

Large capacity torque converter with lock-up provides:

- Quick acceleration
- Lock-up in 2nd, 3rd and 4th gear

Komatsu SmartLoader Logic helps reduce fuel consumption with no decrease in production.

A powerful **Komatsu SAA6D140E-7 engine** provides a net output of 264 kW **357 HP** with up to five percent improved fuel consumption. This engine is EPA Tier 4 Final emissions certified.

Komatsu Variable Geometry Turbocharger (KVG T) uses a hydraulic actuator to provide optimum air flow under all speed and load conditions.

Komatsu Diesel Particulate Filter (KDPF) and Selective Catalytic Reduction (SCR) systems reduce particulate matter and NO_x, while providing automatic regeneration that does not interfere with daily operation.

Fluid neutral or better

Consumption of fuel and diesel exhaust fluid (DEF) is designed to be less than or equivalent to the amount of fuel consumed by the prior model.

Cooling

- Auto-reversing fan is standard
- Hydraulically driven, variable-speed fan
- Wider core coolers resist clogging
- Swing-out fan for easy cleaning

Remote boom and bucket positioners allow kickouts to be set from inside the cab.

Variable displacement piston pumps with Closed-Center Load Sensing System (CLSS) provide quick response and smooth operation to maximize productivity.

Rearview monitoring system (standard)

Advanced diagnostic system continuously monitors machine operation and vital systems to identify machine issues and assist with troubleshooting.

Transmission Mode Select System (3 modes) allows shifting mode to be matched more efficiently to varying work applications.

Enhanced working environment:

- New high capacity, heated, air suspension seat,
- Seat mounted EPC controls with F-N-R switch
- Two 12V power outlets

New front fender is changed from steel to composite material for resistance to scratches and impact.



Full rear fenders (standard) swing open for easy access to maintenance points.

Large LCD color monitor panel:

- 7" high resolution, multi-color screen is easy to read
- Integrated load meter system displays payload data directly on the monitor panel
- Includes an "Ecology" gauge and provides guidance for greater fuel efficiency
- Onboard diagnostics do not require use of a laptop computer
- Easy-to-navigate menus allow operators to change settings, review machine performance records and track periodic maintenance items.

Komatsu Auto Idle Shutdown helps reduce idle time and operating costs.

External mounting of engine air filter (above rear LH fender)

provides easy access for maintenance.

KOMTRAX® equipped machines can send location, Service meter readings and operation maps to a secure website or smart phone utilizing wireless technology. Machines also relay error codes, cautions, maintenance items, fuel & Diesel Exhaust Fluid (DEF) levels, payload data and much more.

Battery disconnect switch allows a technician to disconnect the power supply before servicing the machine.

Operator Identification System can track machine operation for up to 100 operators.

YARD LOADER FEATURES

Proven Design and Technology to help move more material faster, move more trucks out of the yard, and move your business forward...

Large capacity bucket is optimized based on material density, with up to 9.8 yd³ capacity. This helps increase productivity in applications such as truck loading, carrying, stock piling and charging hoppers.

Large capacity bucket cylinder provides increased power and control to help handle big loads.

875/65 Tires increase ground contact area for improved stability. The low profile also reduces sidewall flex for more stability while dumping into trucks or hoppers.

WA5500-8 Yard Loader

**Joystick Steering (Optional)**

helps to reduce operator fatigue in repetitive V-Cycle loading.

Additional Counterweight

helps improve stability, and allows for increased bucket capacity while the contoured shape maximizes ground clearance for stock piling applications.

Brake Cooling System (Front & Rear)

helps control brake temperatures in higher speed applications to ensure optimum performance in load & carry situations.

The WA500-8 Yard Loader is designed to load 20 – 25 ton on-highway trucks with two, even passes. This machine is perfectly suited to move quickly between other yard applications that involve loose/rehandled material such as load & carry, stock piling and charging hoppers.

SPECIFICATIONS



ENGINE

Model..... Komatsu SAA6D140E-7*
 Type..... Water-cooled, 4-cycle
 Aspiration..... Variable geometry turbo-charged, after-cooled, cooled EGR
 Number of cylinders..... 6
 Bore..... 140 mm **5.51"**
 Stroke..... 165 mm **6.50"**
 Piston displacement..... 15.24 ltr **930 in³**
 Governor..... All-speed, electronic
 Horsepower:
 SAE J1995..... Gross 266 kW **357 HP**
 ISO 9249 / SAE J1349..... Net 263 kW **353 HP**
 Rated rpm..... 1900 rpm
 Fan drive method for radiator cooling.....Hydraulic
 Fuel system..... Direct injection
 Lubrication system:
 Method.....Gear pump, force-lubrication
 Filter.....Full-flow type
 Air cleaner..... Dry type with double elements and dust evacuator, plus dust indicator

*EPA Tier 4 Final emissions certified



TRANSMISSION

Torque converter..... three-elements, one-stage, two-phase
 Transmission..... Full-powershift, planetary type

Travel speed	Forward*	Reverse*
1st	7.5 km/h 4.7 mph	8.5 km/h 5.3 mph
2nd	12.9 km/h 8.0 mph (13.1 km/h 8.1 mph)	12.9 km/h 8.0 mph (13.0 km/h 8.1 mph)
3rd	22.2 km/h 13.8 mph (23.7 km/h 14.7 mph)	24.7 km/h 15.3 mph (26.6 km/h 16.5 mph)
4th	35.5 km/h 22.1 mph (37.3 km/h 23.2 mph)	38.0 km/h 23.6 mph (38.0 km/h 23.6 mph)

*P-mode Measured with 29.5-25 tires (:): Lock-up clutch ON



AXLES AND FINAL DRIVES

Drive system.....Four-wheel drive
 Front..... Fixed, full-floating
 Rear..... Center-pin support, full-floating, 20° total oscillation
 Reduction gear.....Spiral bevel gear
 Differential gear..... Conventional type
 Final reduction gear..... Planetary gear, single reduction



BRAKES

Service brakes..... Hydraulically actuated, wet disc brakes actuate on four wheels
 Parking brake..... Wet disc brake
 Emergency brake..... Parking brake is commonly used



STEERING SYSTEM

Type..... Articulated type, fully-hydraulic power steering
 Steering angle..... 36° (40° to max end stop)
 Minimum turning radius at the center of outside tire..... 7050 mm **23' 2"**



HYDRAULIC SYSTEM

Steering system:
 Hydraulic pump..... Piston type
 Capacity..... 120 ltr/min **31.7 U.S. gal/min** at rated rpm
 Relief valve setting..... 24.5 MPa 250 kgf/cm² **3,555 psi**
 Hydraulic cylinders:
 Type..... Double-acting, piston type
 Number of cylinders..... 2
 Bore x stroke..... 100 mm x 486 mm **3.9" x 19.1"**

Loader control:
 Hydraulic pump..... Piston pump
 Capacity..... 320 ltr/min **84.8 U.S. gal/min** at rated rpm
 Relief valve setting..... 34.3 MPa 350 kgf/cm² **4,980 psi**
 Hydraulic cylinders:
 Type..... Double-acting, piston type
 Number of cylinders—bore x stroke:
 Boom cylinder..... 2- 160 mm x 898 mm **6.3" x 35.4"**
 Bucket cylinder..... 1- 185 mm x 675 mm **7.3" x 26.6"**
 Control valve..... 2-spool type
 Control positions:
 Boom..... Raise, hold, lower, and float
 Bucket..... Tilt-back, hold, and dump
 Hydraulic cycle time (rated load in bucket)
 Raise..... 7.2 s
 Dump..... 1.7 s
 Lower (Empty)..... 4.2 s



SERVICE REFILL CAPACITIES

Cooling system..... 110 ltr **29.1 U.S. gal**
 Fuel tank..... 473 ltr **124.9 U.S. gal**
 Engine..... 37 ltr **9.8 U.S. gal**
 Hydraulic system..... 337 ltr **89.0 U.S. gal**
 Axle (each front and rear)..... 95 ltr **25.1 U.S. gal**
 Torque converter and transmission..... 71 ltr **18.8 U.S. gal**
 DEF tank..... 36 ltr **9.5 U.S. gal**



BUCKET SELECTION GUIDE

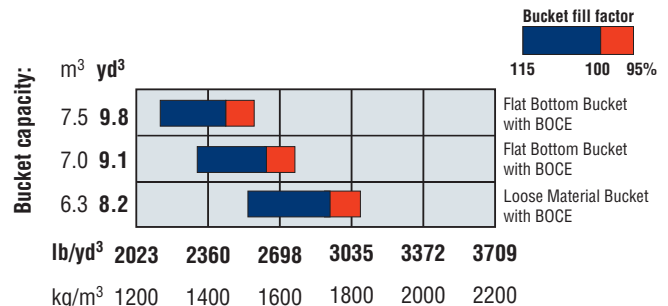



DIMENSIONS

Measured with 875/65-R29 tires

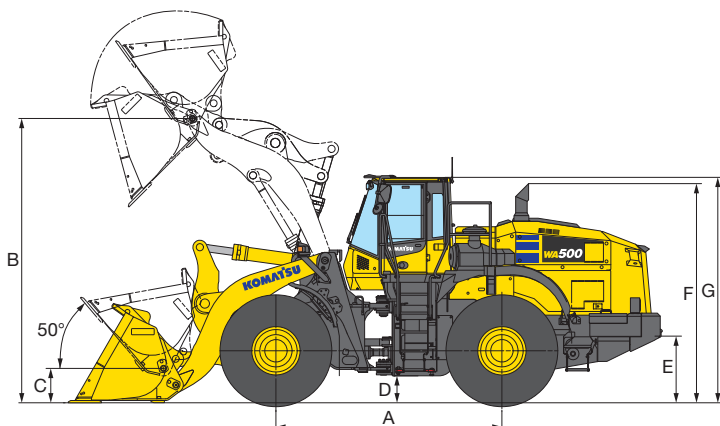

Tread width (center of tread to center of tread)	2400 mm	7'10"
Width over tires	3298 mm	10'10"
A Wheelbase	3780 mm	12'5"
B Hinge pin height, max. height	4755 mm	15'7"
C Hinge pin height, carry position	575 mm	1'11"
D Ground clearance	450 mm	1'6"
E Hitch height	1115 mm	3'8"
F Overall height, top of the stack	3665 mm	12'0"
G Overall height, ROPS cab	3785 mm	12'5"

	Loose Material Bucket	ACS Flat Bottom Bucket	ACS Flat Bottom Bucket	Hensley Flat Bottom Bucket	Hensley Flat Bottom Bucket
	Bolt-on Cutting Edge	Bolt-on Cutting Edge	Bolt-on Cutting Edge	Bolt-on Cutting Edge	Bolt-on Cutting Edge
Bucket capacity: heaped	6.3 m ³	7.0 m ³	7.5 m ³	7.0 m ³	7.5 m ³
	8.2 yd³	9.1 yd³	9.8 yd³	9.2 yd³	9.8 yd³
struck	5.3 m ³	6.0 m ³	6.3 m ³	6.0 m ³	6.3 m ³
	6.9 yd³	7.8 yd³	8.2 yd³	7.8 yd³	8.2 yd³
Bucket width	3400 mm	3581 mm	3581 mm	3581 mm	3581 mm
	11'2"	11'9"	11'9"	11'9"	11'9"
Bucket weight	3485 kg	3581 kg	3654 kg	3582 kg	3714 kg
	7,683 lb	7,895 lb	8,055 lb	7,897 lb	8,187 lb
Dumping clearance, max. height and 45° dump angle* (H)	3210 mm	3162 mm	3123 mm	3171 mm	3123 mm
	10'6"	10'4"	10'3"	10'5"	10'3"
Reach at max. height and 45° dump angle*	1585 mm	1634 mm	1673 mm	1625 mm	1673 mm
	5'2"	5'4"	5'6"	5'4"	5'6"
Reach at 2130 mm 7' clearance and 45° dump angle	2350 mm	2356 mm	2395 mm	2371 mm	2397 mm
	7'8"	7'9"	7'10"	7'9"	7'10"
Reach with arm horizontal and bucket level	3385 mm	3450 mm	3505 mm	3437 mm	3505 mm
	11'1"	11'4"	11'6"	11'3"	11'6"
Operating height (fully raised)	6540 mm	6923 mm	7045 mm	6677 mm	6805 mm
	21'5"	22'9"	23'1"	21'11"	22'4"
Overall length (bucket on ground)	10035 mm	10102 mm	10157 mm	10083 mm	10151 mm
	32'11"	33'2"	33'4"	33'1"	33'4"
Loader clearance circle (bucket at carry, outside corner of bucket)	16550 mm	16693 mm	16722 mm	16688 mm	16723 mm
	54'4"	54'9"	54'10"	54'9"	54'10"
Digging depth:	0°	135 mm	135 mm	135 mm	135 mm
		5"	5"	5"	5"
	10°	455 mm	470 mm	480 mm	467 mm
	1'6"	1'6"	1'7"	1'6"	1'7"
Static tipping load: straight	27828 kg	27572 kg	27488 kg	27714 kg	27571 kg
	61,350 lbs	60,786 lbs	60,601 lbs	61,099 lbs	60,784 lbs
	25117 kg	24861 kg	24776 kg	25002 kg	24859 kg
	55,373 lbs	54,809 lbs	54,622 lbs	55,120 lbs	54,805 lbs
Breakout force	266 kN	257 kN	249 kN	259 kN	249 kN
	27124 kg	26207 kg	25391 kg	26411 kg	25391 kg
	59,799 lb	57,776 lb	55,977 lb	58,226 lb	55,977 lb
Operating weight	36581 kg	36677 kg	36750 kg	36678 kg	36810 kg
	80,647 lbs	80,859 lbs	81,020 lbs	80,861 lbs	81,152 lbs

* At the end of tooth or B.O.C.E.

All dimensions, weights, and performance values based on SAE J732c and J742b standards.

Static tipping load and operating weight shown include lubricant, coolant, full fuel tank, ROPS cab, and operator.

Machine stability and operating weight affected by counterweight, tire size, and other attachments.

Apply the following weight changes to operating weight and static tipping load.



STANDARD EQUIPMENT

- Alternator, 90 A
- Auto shift transmission with mode select system
- Automatic digging system
- Automatic hydraulic-driven fan with automatic reverse rotation
- Back-up alarm
- Batteries, 160 Ah/12 V (2)
- Battery disconnect
- Brake cooling system
- Boom kick-out, in-cab adjustable
- Bucket positioner, upper/lower in-cab adjustable, 3 positions
- Color rear view camera and monitor
- Counterweight, standard and additional for Yard Loader (logging counterweight)
- Electronically Controlled Suspension System (ECSS)
- Engine, Komatsu SAA6D140E-7 diesel
- Engine shut-off system, electric
- Engine shutdown secondary switch
- EPC fingertip controls with F-N-R switch, two levers
- Equipment Management Monitoring System (EMMS)
 - Lights (central warning, brake oil pressure, engine oil pressure, parking brake, cooling fan reverse, KDPF restriction, seat belt caution, Komtrax message)
 - Gauges (Engine water temperature, ecology, Fuel level, DEF levels, Hydraulic oil temperature, speedometer/tachometer)
- Front fenders
- Fuel pre-filter with water separator
- Horn, electric
- Komatsu SmartLoader Logic
- Komatsu Auto Idle Shutdown
- KOMTRAX® Level 5
- Lift cylinders and large capacity bucket cylinder
- Lights
 - Back-up light, LED
 - Stop and tail light, LED
 - Turn signal, two front and two rear with hazard switch
 - Working lights, halogen, two front cab mount
 - Working lights, halogen, two front fender mount
 - Working lights, halogen, two rear
- Load meter*
- Loader linkage with standard lift arm
- Lock-up torque converter
- Parking brake, electric
- Radiator, wider core
- Radiator mask, swing out
- Rear full fenders
- Rear view mirrors, outside (2) inside (2)
- Rims for 29.5-25 tires
- ROPS/FOPS Cab Level 2
 - 2 x DC12V electrical outlets
 - Ashtray
 - Auto air conditioner
 - Cigarette lighter, 24V
 - Color LCD/TFT multi-monitor
 - Cup holder
 - Floor mat
 - Operator seat, reclining, air suspension type, heated
 - Radio, AM/FM with AUX input jack
 - Rear defroster, electric
 - Seatbelt, two-point retractable, 76mm 3" width
 - Space for Lunch box
 - Steering wheel, tilt and telescopic
 - Sun visor, front window
 - Windshield washer and wiper, front with intermittent
 - Windshield washer and wiper, rear
- Service brakes, wet disc type
- Starting motor, 11 kW
- Transmission, four forward and four reverse
- Two-spool valve for boom and bucket control
- Vandalism protection kit

* Restrictions apply based on machine configuration. Load meter is not available for machines with MF monolever, 3rd spool hydraulic arrangement or coupler. Consult your local Komatsu distributor for details.



OPTIONAL EQUIPMENT

- Advanced joystick steering system
- Auxiliary steering (SAE)
- Engine pre-cleaner with extension
- Graco autolube system
- Joystick/wheel steering control system
- Limited slip differential (F&R)
- Mono-lever loader control with transmission F-N-R switch
- Power train guard
- Tires, 875/65-R29 XHAZ L2
- Various bucket options

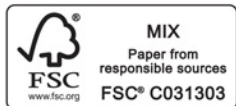

AESS915-01

©2016 Komatsu America Corp.

Printed in USA

AD12(750)OTP

10/17 (EV-3)



Note: All comparisons and claims of improved performance made herein are made with respect to the prior Komatsu model unless otherwise specifically stated.