

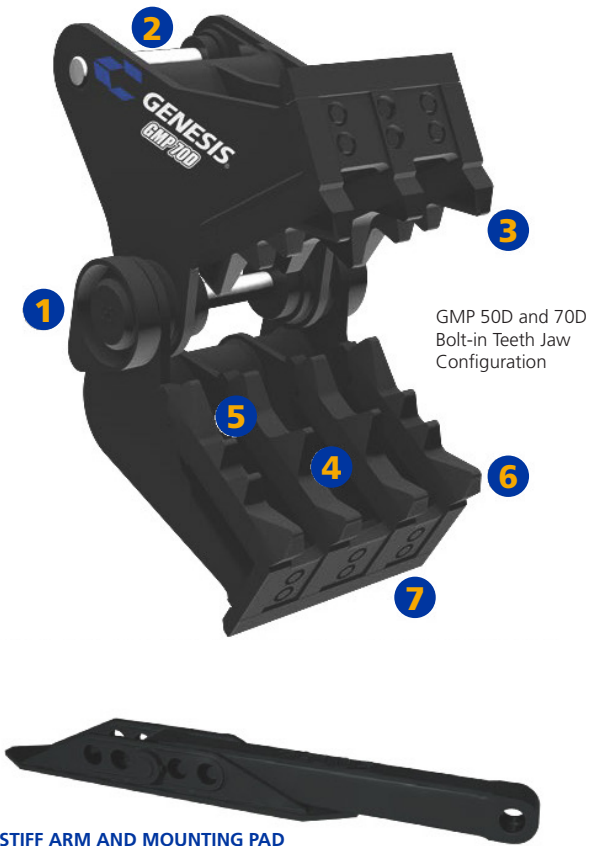

Mechanical Pulverizer D Series (GMP D)

Features

1. The D Series features a multi-machine mounting design for maximum excavator flexibility
2. Extended link pin position provides optimal power
3. Available in two models: With weld-in teeth that can be rebuilt in place for extended life or With bolt-in teeth that are easily replaced in the field for minimal downtime and can be rotated front to back for longer life
4. Pass-through jaw design provides easy material processing and prevents jamming
5. Offset teeth rows maximize the ability to downsize material
6. All teeth extend beyond chin to protect parent steel from wear and abrasion
7. Extended chin blades aid in positioning concrete for processing



GMP 50D and 70D
Bolt-in Teeth Jaw
Configuration

STIFF ARM AND MOUNTING PAD
Comes standard with each GMP D



GMP 50D and 70D
Weld-in Teeth Jaw
Configuration

Applications

- Demolition
- C & D Processing
- Concrete Recycling

Model	Weight* kg (lb)	Jaw Opening** mm (in)	Jaw Depth mm (in)	Moving Jaw Width mm (in)	Fixed Jaw Width mm (in)	Tooth Configuration	Excavator Weight mt (lb)
GMP 50D	2,109 (4,650)	914 (36)	635 (25)	610 (24)	813 (32)	3/4	18-27 (40,000-60,000)
GMP 70D	2,291 (5,050)	1,016 (40)	737 (29)	673 (26.5)	864 (34)	4/5	27-36 (60,000-80,000)
GMP 90D	2,903 (6,400)	1,118 (44)	826 (32.5)	826 (32.5)	1,016 (40)	4/5	36-50 (80,000-110,000)

*Weight includes mounting bracket and stiff arm.

**Jaw opening varies slightly depending on excavator mounting location.
The GMP D is available in black only.



1 866 458 0101
smsequipment.com