

# PERFORMANCE DATA

PAVER (TIER 4f)

BF 300 C-2



Greatest durability



Shorter set-up times



Exemplary efficiency

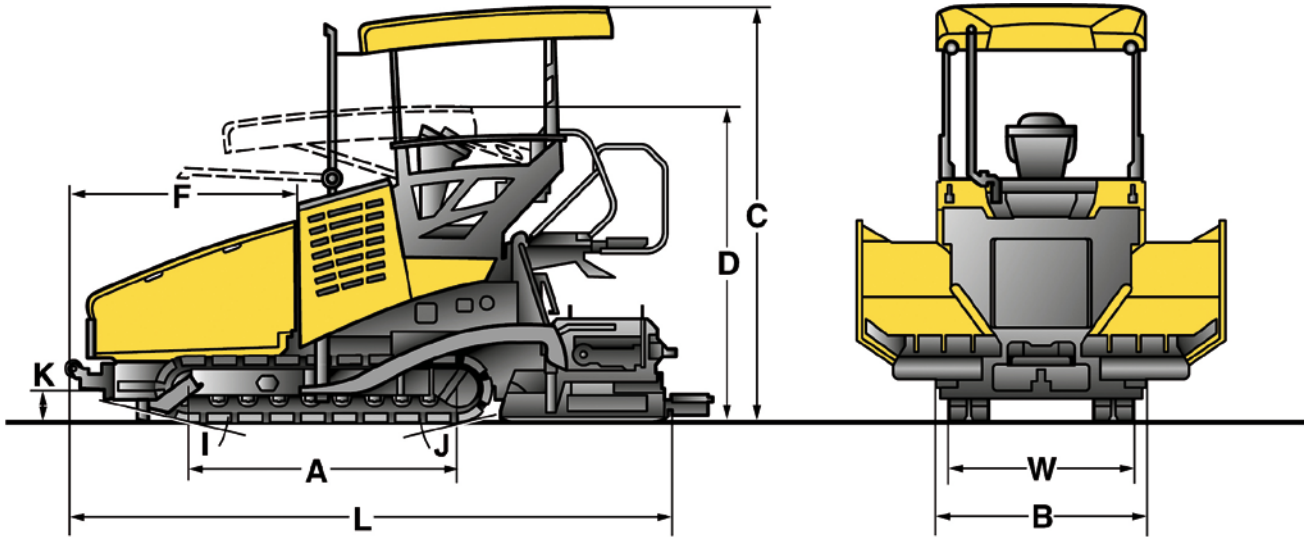

**Dimensions in mm**

	A	B	C	D	F	I	J	K	L	W
<b>BF 300 C-2 S 340-2</b>	2275	1880	3500	3050	1975	12,7°	18,5°	195	5050	1452



Hydraulic front gate – for a clean material flow.



Impact-free docking – dampened bumper.



Save up to 17 % fuel – demand-driven hydraulics – with BOMAG ECOMODE.



Heats up nearly 60 % quicker – unique MAGMALIFE heating system.

## Technical Data

## BOMAG BF 300 C-2

### Weight CECE

With S340-2 V screed / S340-2 TV screed ..... kg 8780 / 9000

### Dimensions

Transport length ..... mm 5050  
Transport width ..... mm 1880  
Transport height ..... mm 3270

### Travel characteristics

Travel speed ..... km/h 0-5  
Working speed ..... m/min<sup>-1</sup> 0-20 variable

### Drive

Engine manufacturer ..... Kubota  
Type ..... V3307-CR-T-EU4  
Emission stage ..... Stage III b / TIER 4f  
Cooling ..... liquid  
Number of cylinders / Displacement ..... cm<sup>3</sup> 4 / 3331  
Rated power ..... kW / HP 54,6 / 75

### Crawler assembly

Total length ..... mm 2273  
Width ..... mm 260

### Hopper

Capacity ..... m<sup>3</sup> 4,8  
Width (wings open) ..... mm 3080  
Width (wings closed) ..... mm 2270  
Length ..... mm 1800  
Filling height (middle) ..... mm 515

### Conveyor

Number ..... 2  
Rotary speed ..... U/min 33  
Individual control ..... Standard  
Reversing operation ..... yes

### Auger

Number ..... 2  
Auger diameter ..... mm 280  
Rotary speed ..... U/min 117  
Reversing operation ..... Standard

### Screed

Basic width retracted ..... mm 1700  
Basic width extended ..... mm 3400  
Min. width with reduction skids ..... mm 700  
Mat thickness ..... mm 250  
Screed plate depth ..... mm 330  
Screed plate thickness ..... mm 12  
Heating ..... electric  
Crown ..... % -2,5 ... +4,5  
Tmaper frequency ..... Hz 0-29  
Vibration frequency ..... Hz 20-58  
Basic weight ..... kg 1500 / 1700  
Max. working width ..... mm 5000

### Filling capacities

Fuel ..... l 95  
Hydraulic oil ..... l 80

## Standard Equipment

### Operator compartment

- SIDEVIEW
- Driver's seat: with swivel and side-shift
- Dashboard protection
- Hydraulic hinged roof
- Digital display for machine Management

### Tractor

- ECOMODE
- Separate control of hopper wings
- Hydraulic, height adjustable auger
- Track scraper
- 2 proportionally controlled and reversible wear-resistant cast augers; screw blades separately replaceable
- 2 independent and reversible scraper belts; high-wear resistant plates
- Rubber track pads

### Screed

- L.C.S. Screed relief and traction increase system
- Screed temperature control
- MAGMALIFE Aluminium heating plates
- MAGMALIFE Automatic screed heating
- Mechanical screed lock
- Crown adjustment
- Side control of auger/scraper belts

### Other

- Tools
- 8 work lights
- Three phase Generator
- Socket 2 x 240 volt

## Optional Equipment

### Operator compartment

- Weather protection for platform
- Seat warmer
- Asphalt steam extraction

### Tractor

- Central lubrication system
- Optional paint finish
- Biologically degradable hydraulic oil
- Hydraulic hopper front flap
- Spring dampened push rollers

### Screed

- Hydraulic crown adjustment
- Hinged side plates
- Heated side plates
- L.C.S. half-sided
- S 340-2 extensions:
  - 350 mm
  - 500 mm
- Reduction shoes

### Levelling systems

- Height and cross-slope sensing by means of ultrasonic or mechanical sensors

### Other

- Fleetmanagement BOMAG TELEMATIC
- Moon-light balloon
- LED working lights



PRE 891 17 010

04072018 Sa03

**BOMAG**  
Hellerwald  
D-56154 Boppard  
Postfach 5162  
D-56149 Boppard  
Tel. (0)6742 - 1000  
Fax (0)6742 - 3090

