

KOMATSU®

PC490LCi-11

Tier 4 Final Engine

HYDRAULIC EXCAVATOR



Photo may include optional equipment.

NET HORSEPOWER

359 HP @ 1900 rpm
268 kW @ 1900 rpm

OPERATING WEIGHT

105,670–107,850 lb
47930–48920 kg

BUCKET CAPACITY

1.47–4.15 yd³
1.12–3.17 m³

PC490LCi

intelligent
MACHINE CONTROL

WALK-AROUND

PC490LCG-11



NET HORSEPOWER
359 HP @ 1900 rpm
268 kW @ 1900 rpm

OPERATING WEIGHT
105,670–107,850 lb
47930–48920 kg

BUCKET CAPACITY
1.47–4.15 yd³
1.12–3.17 m³

Photos may include optional equipment

MAKE EVERY PASS COUNT

Improve your efficiency – less time required to complete excavation to finish grade with intelligent Machine Control (see pg 5).

Semi-automatic operation – next generation technology goes beyond traditional machine guidance (indicate only) type systems.



Innovative

- intelligent Machine Control excavator features semi-automatic operation of work equipment for highly accurate work.
- Large 12.1" (30.7 cm) monitor neatly displays simultaneous information such as magnified fine grading view, 3D view, current as-built status, etc.

Integrated

- Complete factory installed integrated intelligent Machine Control system comes standard with stroke sensing hydraulic cylinders, Global Navigation Satellite System (GNSS) components and an Inertial Measurement Unit (IMU) sensor. All components are validated to Komatsu's rigid quality & durability standards.

Intelligent

- intelligent Machine Control excavator allows the operator to focus on moving material efficiently while semi-automatically tracing the target surface and limiting over-excavation.
- Facing angle compass, light bar and sound guidance aid in ease of operation and bucket positioning.



INTELLIGENT MACHINE CONTROL



Photo may include optional equipment. PC210LCi-11 shown.

intelligent Machine Control

intelligent Machine Control is based on Komatsu's unique sensor package, including stroke sensing hydraulic cylinders, an IMU sensor, and GNSS antennas. It utilizes 3D design data loaded in the control box to accurately check its position against the target. If the bucket hits the target surface,

it is semi-automatically limited to minimize over-excavation. If the operator turns off Auto mode, the machine can be operated with highly accurate, responsive machine guidance (indicate only).



• Auto grade assist

With the auto grade assist function, the operator moves the arm, the boom adjusts the bucket height automatically, tracing the target surface and minimizing digging too deep. This allows the operator to perform rough digging without worrying about the design surface, and to perform fine digging by operating the arm lever only. The working range is extended by holding the lever to move the boom downward.



• Auto stop control

During boom or bucket operation, the work equipment automatically stops when the bucket edge reaches the design surface, thus minimizing damage to the design surface.



• Minimum distance control

The intelligent Machine Control excavator controls the bucket by automatically selecting the point on the bucket closest to the target surface. Should the machine not be facing a sloped surface at a right angle, it will still follow the target surface and minimize digging below it.



Improved Construction Efficiency

Staking, survey and final inspection which is usually done manually, can be reduced with the intelligent Machine Control excavator by setting 3D design data on the control box. Also, use of the facing angle compass can minimize leveling work for the surface on which the machine sits. Even if the machine is inclined while working, the facing angle compass allows the operator to ensure that the machine is facing perpendicular to the target surface. The intelligent Machine Control technology allows the operator to improve work efficiency (i.e. shorter construction time) while minimizing over-excavating the target surface from rough digging to finish grading.

Comparison of construction time based on in-house test of excavation and grading slope surface

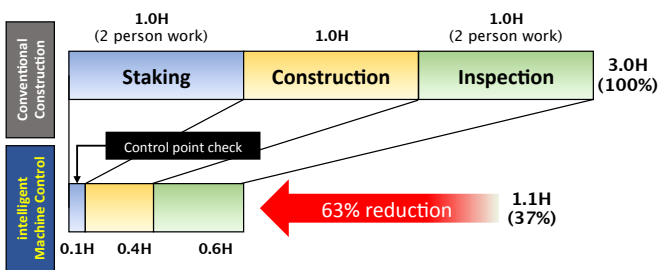

* When used by an expert operator, the Komatsu intelligent Machine Control system increases construction efficiency.
 * The above data does not include design time or working data creation time. The above data are based on in-house construction tests whose conditions may differ from actual construction.



Comparison of slope shaping work

Conventional construction	Intelligent Machine Control
Shaping with reference to finishing stakes	Reduces staking work and the number of assistant workers.

Improved Work Accuracy

The bucket edge/tip position is instantly displayed on the monitor during construction. The large and easy-to-view control box displays information clearly, aiding in highly accurate work. With manual operation and conventional machine guidance, finish grade quality and excavating accurately depends heavily on the skill of the operator. With the intelligent Machine Control excavator, the bucket is automatically limited to follow the target grade without over-excavating.

Relationship between finished surface and allowable value

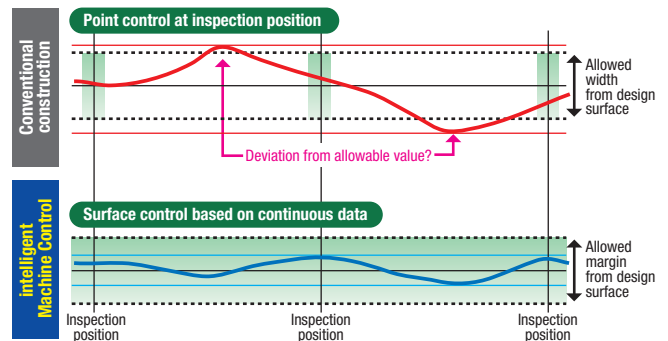

As-Built Surface Track Mapping

Operator can display and check the as-built status and find where to cut and fill.

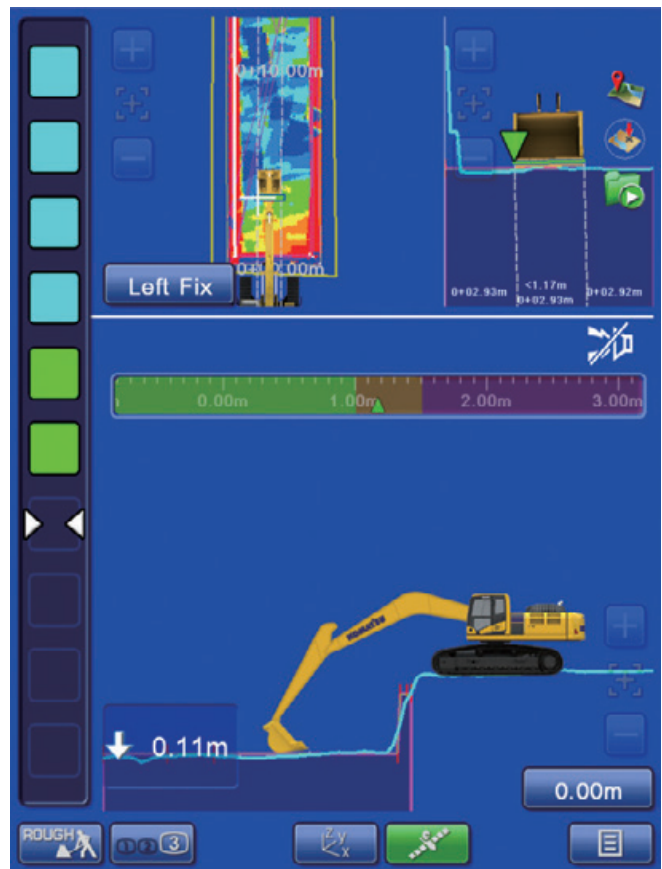

iNTELLIGENT MACHINE CONTROL

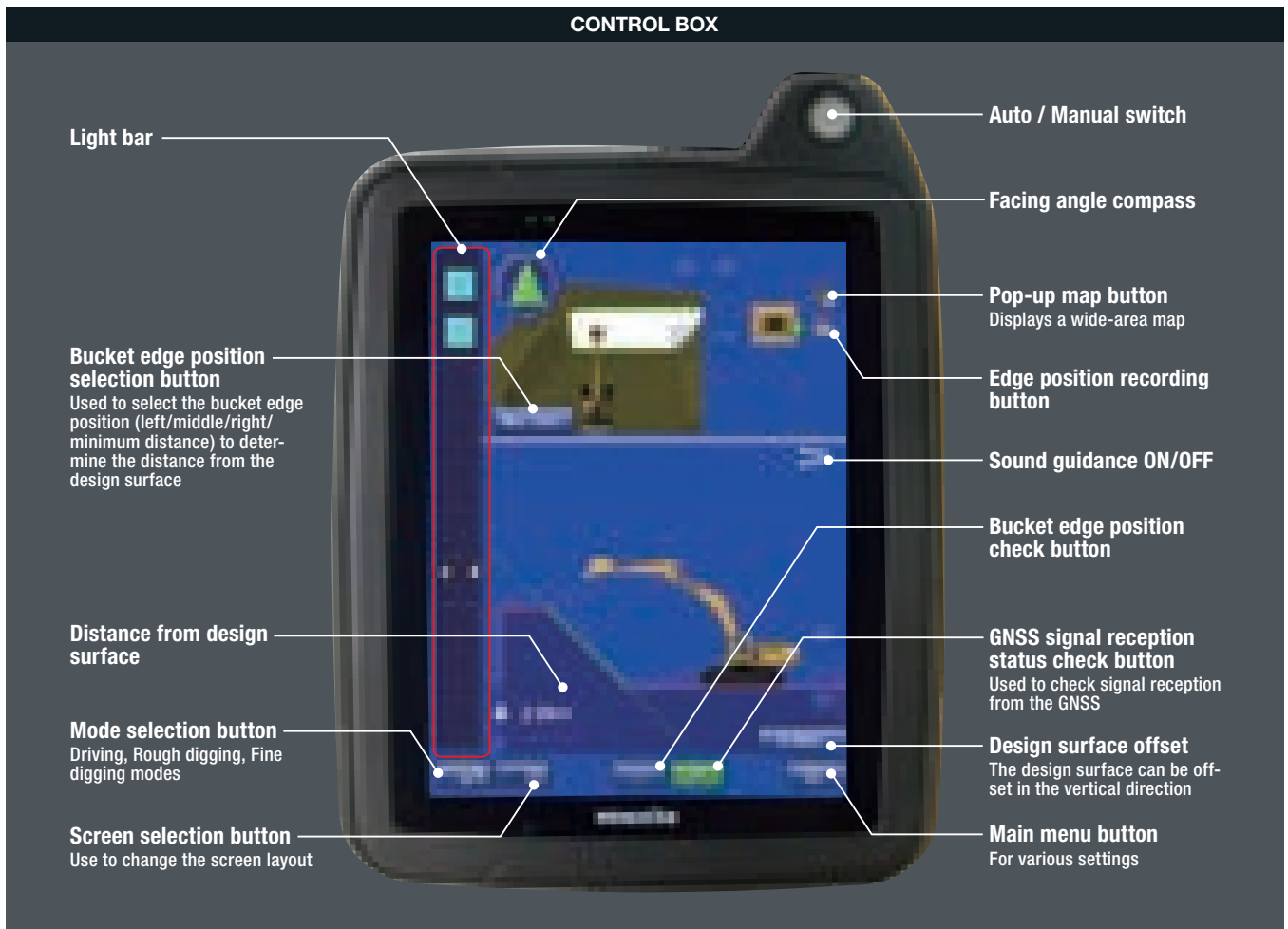

Control Box

The monitor of the Komatsu intelligent Machine Control (control box) uses a large 12.1" (30.7 cm) screen for visibility and ease of use. The simple screen layout displays the necessary information in an easily understood fashion. Touch screen icon interface instead of multi-step menu simplifies operation.

Realistic 3D display

The machine and design surfaces are shown in realistic 3D. The angle and magnification of the views can be changed, which allows the operator to select the optimum view depending on the work conditions.



Enhanced operability of the machine control

Semi-auto/manual mode switching and design surface offset function can be operated with switches on the control levers.

Machine Navigation

Facing angle compass

The orientation and color of the facing angle compass's arrow shows the operator the facing angle of the bucket edge relative to the target surface. This allows the bucket edge to be accurately positioned square with the target surface, which is useful when finishing slopes.



Bucket Edge Guidance with Eyesight and Sound

Light bar

Colors show the bucket edge position relative to the target surface. Since the light bar is located on the left side of the screen, the bucket edge position can be viewed simply while operating, which increases the work efficiency.



Sound guidance

The operator can recognize the target surfaces not only by eyesight, but also by sound. Unique tones can be programmed for various bucket edge distances from the target surface.





Factory installed Komatsu intelligent Machine Control components



Control box
A large, easy-to-view monitor and unique interface designed for Komatsu intelligent Machine Control.

Proportional control levers

GNSS antenna

Stroke sensing hydraulic cylinder
A stroke sensor is built into the cylinder. This sensor provides accurate, real time bucket position which is immediately displayed on the control box, speeding up your work.

Inertial Measurement Unit (IMU)
Inertial Measurement Unit (IMU) detects machine posture for high accuracy finishing work.

GNSS receiver

TOPCON Sitelink 3D Enterprise

The Sitelink 3D Enterprise connects the office and machine via a network, visualize the worksite clearly.



Transmission of design data from office to machine

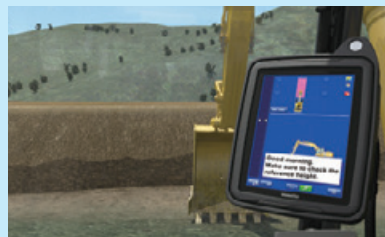

Sending messages from office to machine or vice versa



Progress information and as-built data can be sent to the office from the machine in real time.

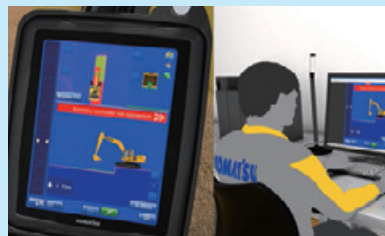

Remote assistance function enables troubleshooting from anywhere via the internet.

Please contact your local Topcon dealer for details.

PERFORMANCE FEATURES

KOMATSU NEW ENGINE TECHNOLOGIES

New Tier 4 Final Engine

The Komatsu SAA6D125E-7 engine is EPA Tier 4 Final emissions certified and provides exceptional performance while reducing fuel consumption. Based on Komatsu proprietary technologies developed over many years, this new diesel engine reduces nitrogen oxides (NOx) by more than 80% when compared to Tier 4 interim levels. Through the in-house development and production of engines, electronics, and hydraulic components, Komatsu has achieved great advancements in technology, providing high levels of performance and efficiency in virtually all applications.

Technologies Applied to New Engine

Heavy-duty aftertreatment system

This new system combines a Komatsu Diesel Particulate Filter (KDPF) and Selective Catalytic Reduction (SCR). The SCR NOx reduction system injects the correct amount of Diesel Exhaust Fluid (DEF) at the proper rate, thereby decomposing NOx into non-toxic water vapor (H₂O) and nitrogen gas (N₂).

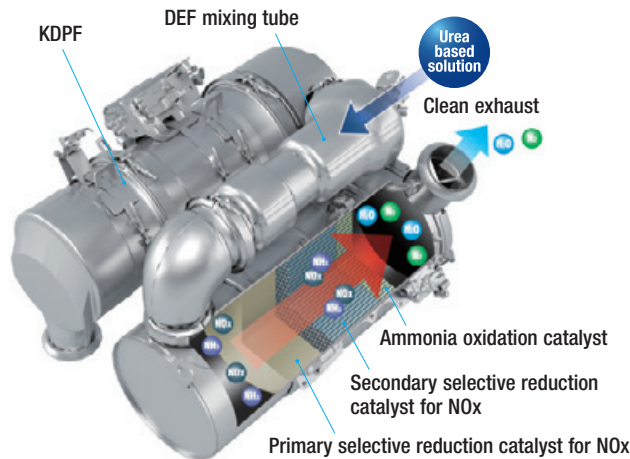

Heavy-duty cooled Exhaust Gas Recirculation (EGR) system

The system recirculates a portion of exhaust gas into the air intake and lowers combustion temperatures, thereby reducing NOx emissions. EGR gas flow has been decreased for Tier 4 Final with the addition of SCR technology. The system achieves a dynamic reduction of NOx, while helping reduce fuel consumption below Tier 4 Interim levels.

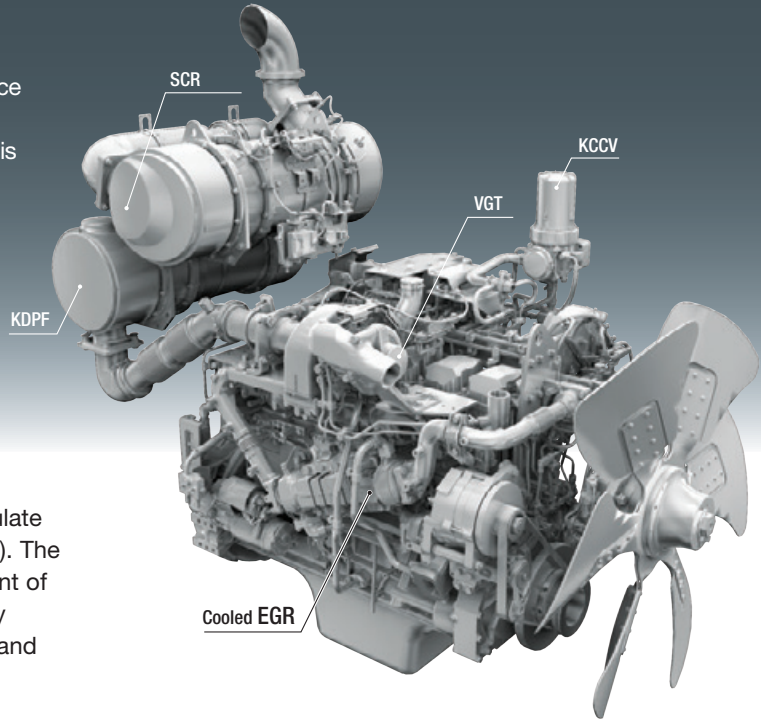
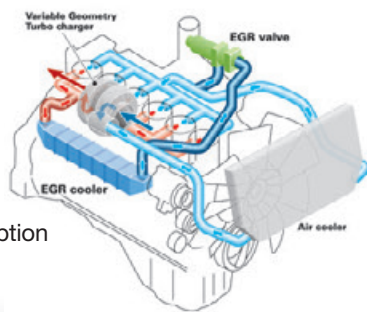

Advanced Electronic Control System

The electronic control system performs high-speed processing of all signals from sensors installed in the vehicle providing total control of equipment in all conditions of use. Engine condition information is displayed via an on-board network to the monitor inside the cab, providing necessary information to the operator. Additionally, managing the information via KOMTRAX helps customers keep up with required maintenance.

Variable Geometry Turbocharger (VGT) system

The system features proven Komatsu design hydraulic technology for variable control of air-flow and supplies optimal air according to load conditions. The upgraded version provides better exhaust temperature management.

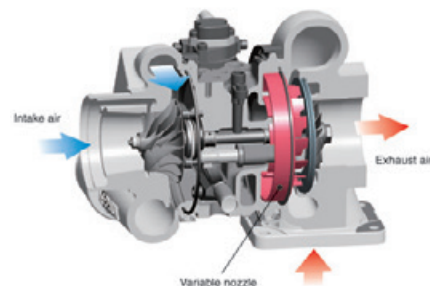



Komatsu Auto Idle Shutdown

Komatsu auto idle shutdown automatically shuts the engine down after idling for a set period of time to reduce unnecessary fuel consumption and exhaust emissions. The amount of time before the engine is shutdown can be easily programmed from 5 to 60 minutes.



Heavy-Duty High-Pressure Common Rail (HPCR) Fuel Injection System

The system is designed to achieve an optimal injection of high-pressure fuel by means of computerized control, providing close to complete combustion to reduce PM emissions. While this technology is already used in current engines, the new system uses high pressure injection, thereby reducing both PM emissions and fuel consumption over the entire range of engine operating conditions. The Tier 4 Final engine has advanced fuel injection timing for reduced fuel consumption and lower soot levels.

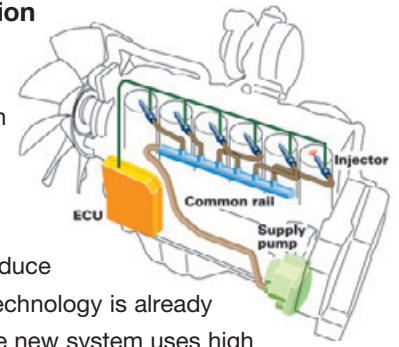

PERFORMANCE FEATURES

Enhanced Productivity

The PC490LCi-11's enhanced P Mode provides more hydraulic flow and increases productivity.

Productivity

Up to 13% increase

(compared to the PC490LC-10 in standard P Mode)

P mode (90° swing and loading onto truck)

- | | |
|------------------------------------|---------------------------------|
| 1 Large counterweight | 6 Reinforced center frame |
| 2 High capacity swing bearing | 7 HD carrier rollers and idlers |
| 3 Reinforced track links and shoes | 8 Reinforced crawler frames |
| 4 Large final drive | 9 Reinforced revolving frame |
| 5 HD sprockets | 10 Track roller guards |
| | 11 Deck guard |
| | 12 Center frame swivel guard |

Increased Work Efficiency

Large digging force

With the one-touch Power Max. function digging force has been further increased. (8.5 seconds of operation)

Maximum arm crowd force (ISO)

200 kN(20.4t) ➔ **214 kN(21.8t) 7% UP**
(with Power Max.)

Maximum bucket digging force (ISO)

256 kN(26.1t) ➔ **275 kN(28.0t) 7% UP**
(with Power Max.)

Measured with Power Max. function, 3380 mm arm and ISO rating

Faster arm cycle speeds

Two return hoses improve arm cylinder hydraulic flow for faster arm out performance.

Two boom mode settings for boom function

- Smooth boom mode provides easy operation for gathering material or scraping down.
- Power boom mode maximizes digging force for more effective excavating.



PC490LCi-11



Hydraulic Variable Speed Fan

The electronic control system sets the rotation speed of the cooling fan according to the coolant, hydraulic oil, and ambient temperatures; effectively uses the engine output to reduce wasteful fuel consumption; and reduces noise during low-speed fan operation.



Drawbar Pull

The Komatsu designed final drives and undercarriage provide high drawbar pull for good maneuverability and performance when working on adverse grades or soft ground.



Large Displacement High Efficiency Pump

Large displacement hydraulic implement pumps provide high flow output at lower engine RPM as well as operation at the most efficient engine speed.



Working Mode Selection

The PC490LCi-11 excavator is equipped with six working modes (P, E, L, B, ATT/P and ATT/E). Each mode is designed to match engine speed, pump flow, and system pressure to the application. The PC490LCi-11 features an attachment mode (ATT/E) that allows operators to run attachments while in Economy mode.

Working Mode	Application	Advantage
P	Power mode	<ul style="list-style-type: none"> •Maximum production/power •Fast cycle times
E	Economy mode	<ul style="list-style-type: none"> •Good cycle times •Better fuel economy
L	Lifting mode	<ul style="list-style-type: none"> •Increases hydraulic pressure
B	Breaker mode	<ul style="list-style-type: none"> •Optimum engine rpm, hydraulic flow
ATT/P	Attachment Power mode	<ul style="list-style-type: none"> •Optimum engine rpm, hydraulic flow, 2-way •Power mode
ATT/E	Attachment Economy mode	<ul style="list-style-type: none"> •Optimum engine rpm, hydraulic flow, 2-way •Economy mode

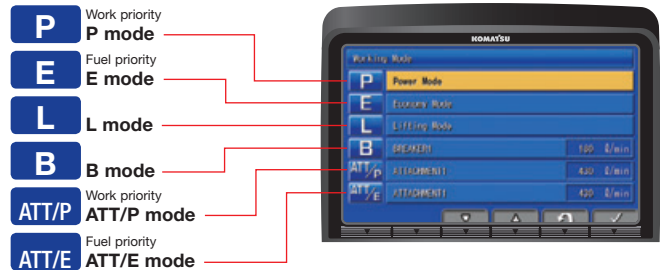

High Rigidity Work Equipment

Booms and arms are constructed with thick plates of high tensile strength steel. In addition, these structures are designed with large cross sectional areas and large one piece castings in the boom foot, the boom tip, and the arm tip. The result is work equipment that exhibits long term durability and high resistance to bending and torsional stress. A standard HD boom design provides increased strength and reliability.



WORKING ENVIRONMENT

PC490LGF-11

LARGE HIGH RESOLUTION LCD MONITOR



New Monitor Panel Interface Design

An updated large high resolution LCD color monitor enables accurate and smooth work. The interface has been redesigned to display key machine information in a new user friendly interface. A rear view camera and a DEF level gauge display have been added to the default main screen. The interface has a function that enables the main screen mode to be switched, thus enabling the optimum screen information for the particular work situation to be displayed.

Indicators

- | | |
|------------------------------------|-----------------------------|
| 1 Auto-decelerator | 8 Fuel gauge |
| 2 Working mode | 9 DEF level gauge |
| 3 Travel speed | 10 Service meter, clock |
| 4 Ecology gauge | 11 Fuel consumption gauge |
| 5 Camera display | 12 Guidance icon |
| 6 Engine coolant temperature gauge | 13 Function switches |
| 7 Hydraulic oil temperature gauge | 14 Camera direction display |
| | 15 DEF level caution lamp |

Basic operation switches

- | | |
|-------------------------|-------------------------|
| 1 Auto-decelerator | 4 Buzzer cancel |
| 2 Working mode selector | 5 Wiper |
| 3 Travel speed selector | 6 Window washer |
| | 7 Auto climate controls |

Switchable Display Modes

The main screen display mode can be changed by pressing the F3 key.

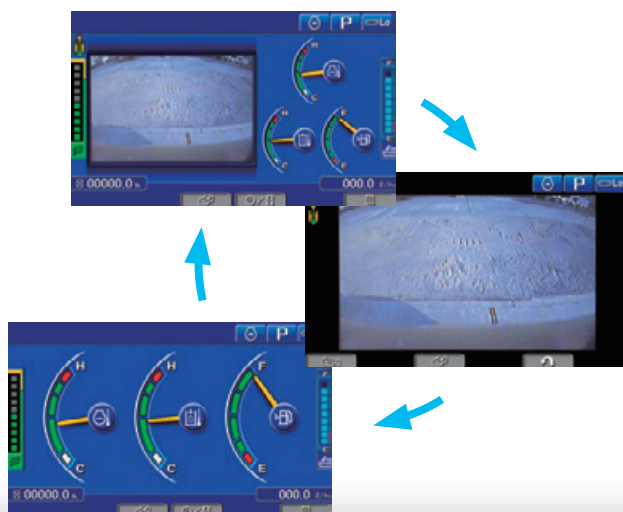

Visual user menu

Pressing the F6 key on the main screen displays the user menu screen. The menus are grouped for each function, and use easy-to-understand icons which enable the machine to be operated easily.



- 1 Energy saving guidance
- 2 Machine settings
- 3 Aftertreatment devices regeneration
- 4 SCR information
- 5 Maintenance
- 6 Monitor setting
- 7 Message check

Support Efficiency Improvement

Ecology guidance

While the machine is operating, ecology guidance pops up on the monitor screen to notify the operator of the status of the machine in real time.

Ecology gauge & fuel consumption gauge

The monitor screen is provided with an ecology gauge and also a fuel consumption gauge which is displayed continuously. In addition, the operator can set any desired target value of fuel consumption (within the range of the green display), enabling the machine to be operated with better fuel economy.



Ecology gauge Fuel consumption gauge
Ecology guidance

Operation record, fuel consumption history, and ecology guidance record

The ecology guidance menu enables the operator to check the operation record, fuel consumption history and ecology guidance record from the ecology guidance menu, using a single touch, thus assisting operators with reducing total fuel consumption.



Operation record



Fuel consumption history

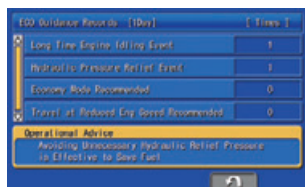

Ecology guidance record

Operator Identification Function

An operator identification ID can be set up for each operator, and used to manage operation information of individual machines using KOMTRAX data. Data sent from KOMTRAX can be used to analyze operation status by operator as well as by machine.



WORKING ENVIRONMENT



Photo may include optional equipment. PC210LCi-11 shown.

Comfortable Working Space

Wide spacious cab

The wide spacious cab includes a heated air suspension seat with reclining backrest. The seat height and position are easily adjusted using a pull-up lever. The armrest position is easily adjusted together with the console. Reclining the seat further enables it to be fully laid back with the headrest attached.

Arm rest with simple height adjustment function

A knob and plunger on the armrests allows easy height adjustment without the use of tools.



Low vibration with cab damper mounting

Automatic climate control

Pressurized cab

Auxiliary input jack

Connecting a regular audio device to the auxiliary jack allows the operator to hear the sound from the stereo speakers installed in the cab.



Standard Equipment

Sliding window glass (left side)



Lockout Tagout Ready

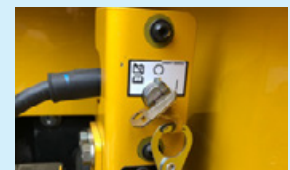

Remote intermittent wiper with windshield washer

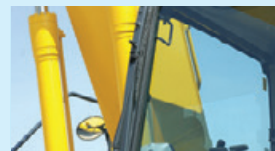

Tie Off Points Standard (ISO 14567)

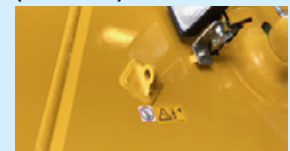

Opening & closing skylight



Magazine box & cup holder



Defroster (conforms to the ISO standard)



One-touch storable front window lower glass



MAINTENANCE FEATURES



Centralized engine check points

Locations of the engine oil check and filters are integrated into one side to allow easy maintenance and service.



Battery disconnect switch

A standard battery disconnect switch allows a technician to disconnect the power supply and lock out before servicing the machine.



Easy cleaning of cooling unit

Reverse-rotation function of the hydraulic driven fan facilitates cleaning of the cooling unit.

Fuel pre-filter with water separator

Electric fuel priming pump

High efficiency fuel filter with water separator

Easy access to engine oil filter, engine oil, Ecology drain valve, fuel drain valve and water separator drain valve

Cab air filter

Washable cab floormat

Sloping track frame



MAINTENANCE FEATURES

Long-life oils, filters

High performance filters are used in the hydraulic circuit and engine. By increasing the oil and filter replacement intervals, maintenance costs can be significantly reduced.

Engine oil & Engine oil filter	every 500 hours
Hydraulic oil	every 5000 hours
Hydraulic oil filter	every 1000 hours



Hydraulic oil filter
(Ecology-white element)

Large capacity air cleaner

Large capacity air cleaner is comparable to that of larger machines. The larger air cleaner can extend air cleaner life during long-term operation and helps prevent early clogging, and resulting power loss. A radial seal design is used for reliability.



Diesel Exhaust Fluid (DEF) tank

A large tank volume extends operating time before refilling and is installed on the right front stairway for ease of access.

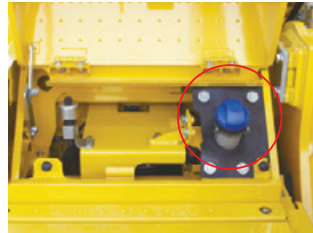

DT-type connectors

Sealed DT-type electrical connectors provide high reliability, water and dust resistance.

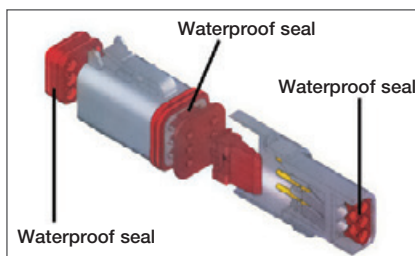

Maintenance Information

“Maintenance time caution lamp” display

When the remaining time to maintenance becomes less than 30 hours*, a maintenance time monitor appears. Pressing the F6 key switches the monitor to the maintenance screen.

* : The setting can be changed within the range between 10 and 200 hours.



Maintenance screen

Manual Stationary Regeneration

Under most conditions, active regeneration will occur automatically with no effect on machine operation. In case the operator needs to disable active regeneration or initiate a manual stationary regeneration, this can be easily accomplished through the monitor panel. A soot level indicator is displayed to show how much soot is trapped in the KDPF.



Soot level indicator

Aftertreatment device regeneration screen

Supports the DEF level and refill timing

The DEF level gauge is displayed continuously on the right side of the monitor screen. In addition, when DEF level is low, DEF low level guidance messages appear in pop up displays to inform the operator in real time.



DEF level gauge

DEF low level guidance

GENERAL FEATURES

ROPS CAB STRUCTURE

ROPS Cab (ISO 12117-2)

The machine is equipped with a ROPS cab that conforms to ISO 12117-2 for excavators as standard equipment. It also satisfies the requirements for Level 1 Operator Protective Guard (OPG) and top guard (ISO 10262).



Rear View Monitoring System

A new rear view monitoring system display has a rear view camera image that is continuously displayed together with the gauges and important vehicle information. This enables the operator to carry out work while easily checking the surrounding area.

Rear view camera



Rear view image on monitor



Low Vibration with Viscous Cab Mounts

The PC490LCi-11 uses viscous mounts for the cab that incorporate a longer stroke and the addition of a spring. The cab damper mounting combined with a high rigidity deck reduces vibration at the operator's seat.

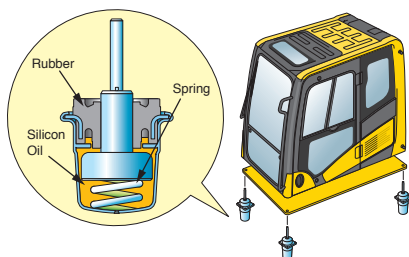

General Features

Secondary engine shut down switch at base of seat to shutdown the engine.



Lock lever

Seat belt retractable

Tempered & tinted glass

Large mirrors

Slip-resistant plates

Thermal and fan guards

Pump/engine room partition

Travel alarm

Large cab entrance step

Left and right side hand rails



Seat belt caution indicator



KOMATSU PARTS & SERVICE SUPPORT



KOMATSU CARE

Program Includes:

*The PC490LCi-11 comes standard with complimentary factory scheduled maintenance for the first 3 Years or 2,000 Hours, whichever comes first.

Planned Maintenance Intervals at:

500/1000/1500/2000 hour intervals. (250 hr. initial interval for some products) Complimentary Maintenance Interval includes: Replacement of Oils & Fluid Filters with genuine Komatsu Parts, 50-Point inspection, Komatsu Oil & Wear Analysis Sampling (KOWA) / Travel & Mileage (distance set by distributor; additional charges may apply)

Benefits of Using Komatsu CARE

- Assurance of Proper Maintenance with OEM Parts & Service
- Increased Uptime & Efficiency
- Factory Certified Technicians Performing Work
- Cost of Ownership Savings
- Transferable Upon Resale

Complimentary KDPF Exchanges

The PC490LCi-11 comes standard with 2 Complimentary KDPF Exchange units for the first 5 Years or 9000 hours whichever comes first. The suggested KDPF Exchange unit service intervals are 4500 hours & 9000 hours. End user must have authorized Komatsu distributor perform the removal & installation of the KDPF.

Complimentary SCR Maintenance

The PC490LCi-11 also includes 2 factory recommended services of the Selective Catalytic Reduction (SCR) Diesel Exhaust Fluid (DEF) system during the first 5 Years or 9000 hours whichever comes first. The service includes factory recommended DEF tank flush & strainer cleaning at the suggested service intervals of 4500 hours & 9000 hours.

Komatsu CARE® – Extended Coverage

- Extended Coverage can provide peace of mind by protecting customers from unplanned expenses that effect cash flow
- Purchasing extended coverage locks-in the cost of covered parts and labor for the coverage period and helps turn these into fixed costs



Komatsu Parts Support

- 24/7/365 to fulfill your parts needs
- 9 parts Distribution Centers strategically located across the U.S. and Canada
- Distributor network of more than 300 locations across U.S. and Canada to serve you
- Online part ordering through Komatsu eParts
- Remanufactured components with same-as-new warranties at a significant cost reduction



Komatsu Oil and Wear Analysis (KOWA)

- KOWA detects fuel dilution, coolant leaks, and measures wear metals
- Proactively maintain your equipment
- Maximize availability and performance
- Can identify potential problems before they lead to major repairs
- Reduce life cycle cost by extending component life

Interval PM	500	1000	1500	2000
KOWA SAMPLING – (Engine, Hydraulics, Swing Circle, L & R Final Drives)	✓	✓	✓	✓
LUBRICATE MACHINE	✓	✓	✓	✓
LUBRICATE SWING CIRCLE	✓	✓	✓	✓
CHECK SWING PINION GREASE LEVEL AND ADD, WHEN NECESSARY	✓	✓	✓	✓
CHANGE ENGINE OIL	✓	✓	✓	✓
REPLACE ENGINE OIL FILTER	✓	✓	✓	✓
REPLACE FUEL PRE-FILTER	✓	✓	✓	✓
REPLACE AC FRESH & RECIRC AIR FILTERS	✓	✓	✓	✓
CLEAN AIR CLEANER ELEMENT	✓	✓	✓	✓
DRAIN SEDIMENT FROM FUEL TANK	✓	✓	✓	✓
COMPLETE 50 POINT INSPECTION FORM; LEAVE PINK COPY WITH CUSTOMER OR IN CAB	✓	✓	✓	✓
RESET MONITOR PANEL MAINTENANCE COUNTER FOR APPROPRIATE ITEMS	✓	✓	✓	✓
REPLACE HYDRAULIC TANK BREATHER ELEMENT		✓		✓
CHECK OIL LEVEL IN DAMPER CASE, ADD WHEN NECESSARY		✓		✓
REPLACE MAIN FUEL FILTER		✓		✓
REPLACE HYDRAULIC OIL FILTER ELEMENT		✓		✓
REPLACE AdBlue®/DEF TANK BREATHER ELEMENT		✓		✓
REPLACE ADDITIONAL HYDRAULIC OIL FILTER ELEMENT		✓		✓
CHANGE SWING MACHINERY OIL		✓		✓
CLEAN HYDRAULIC TANK STRAINER (REPLACE O-RING)				✓
REPLACE KCCV FILTER ELEMENT				✓
REPLACE AdBlue®/DEF FILTER ELEMENT				✓
CHANGE FINAL DRIVE OIL				✓
FACTORY TRAINED TECHNICIAN LABOR	✓	✓	✓	✓
2 KDPF Exchanges at 4,500 Hrs and 9,000 Hrs.				
2 SCR System Maintenance Services at 4,500 Hrs. and 9000 Hrs.				

* Certain exclusions and limitations apply. Refer to the customer certificate for complete program details and eligibility. Komatsu® and Komatsu Care® are registered trademarks of Komatsu Ltd. Copyright 2018 Komatsu America Corp.

PC490LCi-11

KOMTRAX EQUIPMENT MONITORING



GET THE WHOLE STORY WITH
KOMTRAX[®]

✓ WHAT

- KOMTRAX is Komatsu's remote equipment monitoring and management system
- KOMTRAX **continuously monitors and records** machine health and operational data
- Information such as fuel consumption, utilization, and a detailed history **lowering owning and operating cost**

✓ WHO

- KOMTRAX is **standard** equipment on all Komatsu construction products

✓ WHEN

- Know when your machines are **running or idling** and make decisions that will improve your fleet utilization
- Detailed movement records ensure you know when and where your equipment is moved
- Up to date records allow you to **know when maintenance is due** and help you plan for future maintenance needs

✓ WHERE

- KOMTRAX data **can be accessed virtually anywhere** through your computer, the web or your smart phone
- Automatic alerts keep fleet managers up to date on the latest machine notifications

✓ WHY

- Knowledge is power - **make informed decisions** to manage your fleet better
- Knowing your idle time and fuel consumption will help maximize your machine efficiency
- **Take control of your equipment** - any time, anywhere



Photo may include optional equipment.



KOMTRAX[®]

For construction and compact equipment.

SPECIFICATIONS



ENGINE

Model.....Komatsu SAA6D125E-7*
 Type.....Water-cooled, 4-cycle, direct injection
 Aspiration.....Variable Geometry Turbocharger
 with air-to-air aftercooled EGR
 Number of cylinders..... 6
 Bore..... 125 mm **4.92"**
 Stroke..... 150 mm **5.91"**
 Piston displacement..... 11.04 ltr **674 in³**
 Horsepower:
 SAE J1995.....Gross 270 kW **362 HP**
 ISO 9249 / SAE J1349.....Net 268 kW **359 HP**
 Rated rpm..... 1900

Governor.....All-speed control, electronic
 Fan drive method for radiator cooling.....Hydraulic

*EPA Tier 4 Final emissions certified



HYDRAULICS

Type ..HydrauMind (Hydraulic Mechanical Intelligence) system,
 closed-center system with
 load sensing valve and pressure compensated valves,
 6 selectable working modes

Main pump:

Pumps for.....Boom, arm, bucket, swing, and travel circuits
 Type.....Variable displacement axial piston type
 Maximum flow..... 780 ltr/min **206 gal/min**

Hydraulic motors:

Travel..... 2 x axial piston motor with parking brake
 Swing..... 1 x axial piston motor with swing holding brake

Relief valve setting:

Implement circuits..... 37.3 MPa 380 kgf/cm² **5,400 psi**
 Travel circuit..... 37.3 MPa 380 kgf/cm² **5,400 psi**
 Swing circuit..... 27.9 MPa 285 kgf/cm² **4,050 psi**
 Pilot circuit..... 3.2 MPa 33 kgf/cm² **470 psi**

Hydraulic cylinders:

(Number of cylinders – bore x stroke x rod diameter)

Boom..... 2-160 mm x 1570 mm x 110 mm **6.3" x 61.8" x 4.3"**
 Arm..... 1-185 mm x 1820 mm x 120 mm **7.3" x 71.7" x 4.7"**
 Bucket..... 1-160 mm x 1270 mm x 110 mm **6.3" x 50" x 4.3"**



DRIVES AND BRAKES

Steering control.....Two lever with pedals
 Drive method.....Hydrostatic
 Maximum drawbar pull..... 329 kN 33510 kgf **73,880 lbf**
 Gradeability..... 70%, 35°
 Maximum travel speed (auto shift):

High..... 5.5 km/h **3.4 mph**
 Mid..... 4.2 km/h **2.6 mph**
 Low..... 3.0 km/h **1.9 mph**

Service brake.....Hydraulic lock
 Parking brake.....Mechanical disc



SWING SYSTEM

Driven by.....Hydraulic motor
 Swing reduction.....Planetary gear
 Swing circle lubrication.....Grease-bathed
 Service brake.....Hydraulic lock
 Holding brake/Swing lock.....Mechanical disc brake
 Swing speed.....9.0 rpm
 Swing torque..... 13414 kg•m **97,024 ft lbs**



UNDERCARRIAGE

Center frame.....X-frame
 Track frame.....Box-section
 Track type.....Sealed
 Track adjuster.....Hydraulic
 Number of shoes (each side)..... 49
 Number of carrier rollers (each side)..... 2
 Number of track rollers (each side)..... 8



COOLANT & LUBRICANT CAPACITY (REFILLING)

Fuel tank..... 650 ltr **172 U.S. gal**
 Radiator..... 47.0 ltr **12.4 U.S. gal**
 Engine..... 38 ltr **10.0 U.S. gal**
 Final drive, each side..... 11.0 ltr **2.9 U.S. gal**
 Swing drive..... 20.0 ltr **5.3 U.S. gal**
 Hydraulic tank..... 248 ltr **65.5 U.S. gal**
 Diesel Exhaust Fluid (DEF) tank..... 39 ltr **10.3 U.S. gal**



OPERATING WEIGHT (APPROXIMATE)

Operating weight includes 7060 mm **23'2"** one-piece HD boom, 3380 mm **11'1"** arm, SAE heaped 2.25 m³ **2.94 yd³** bucket, rated capacity of lubricants, coolant, full fuel tank, operator, and standard equipment.

Triple-Grouser Shoes	Fixed Gauge	
	Operating Weight	Ground Pressure
700 mm 28"	47930 kg 105,670 lb	0.73 kg/cm ² 10.38 psi
800 mm 31.5"	48430 kg 106,770 lb	0.65 kg/cm ² 9.20 psi
900 mm 35.5"	48920 kg 107,850 lb	0.58 kg/cm ² 8.32 psi



WORKING FORCES

	Arm Length	3380 mm 11'1"	4000 mm 13'1"
ISO rating	Bucket	275 kN	275 kN
	digging force	28000 kgf / 61,730 lb	28000 kgf / 61,730 lb
	Arm	214 kN	190 kN
SAE rating	crowd force	21800 kgf / 48,060 lb	19400 kgf / 42,770 lb
	Bucket	239 kN	239 kN
	digging force	24400 kgf / 53,790 lb	24400 kgf / 53,790 lb
SAE rating	Arm	205 kN	184 kN
	crowd force	20900 kgf / 46,080 lb	18800 kgf / 41,450 lb

Component Weights

Arm including bucket cylinder and linkage
 3380 mm **11'1"** arm assembly..... 2141 kg **4,720 lb**
 4000 mm **13'1"** arm assembly..... 2408 kg **5,309 lb**

One piece HD boom including arm cylinder
 7060 mm **23'2"** boom assembles..... 4017 kg **8,856 lb**
 Boom cylinders x 2..... 366 kg **807 lb**
 Counterweight (standard)..... 9573 kg **21,105 lb**
 2.25 m³ **2.94 yd³** bucket - 54" width..... 1867 kg **4,117 lb**



DIMENSIONS

	Arm Length	3380 mm	11'1"	4000 mm	13'1"
A	Overall length	11930 mm	39'2"	11950 mm	39'2"
B	Length on ground (transport)	6660 mm	21'10"	6330 mm	20'9"
C	Overall height (to top of boom)*	3635 mm	11'11"	3885 mm	12'9"
D	Overall width	3640 mm	11'11"		
E	Overall height (to top of cab)*	3360 mm	11'0"		
F	Overall height (to top of handrail)*	3630 mm	11'11"		
G	Overall height (to top of GNSS Antenna)*	3705 mm	12'2"		
H	Ground clearance, counterweight	1385 mm	4'7"		
I	Ground clearance, minimum	700 mm	2'4"		
J	Tail swing radius	3645 mm	12'0"		
K	Track length on ground	4350 mm	14'3"		
L	Track length	5385 mm	17'8"		
M	Track gauge	2740 mm	9'0"		
N	700 mm 28"	3440 mm	11'2"		
	800 mm 31.5"	3540 mm	11'6"		
	900 mm 35.5"	3640 mm	11'11"		
O	Shoe width	900 mm	35.5"		
P	Grouser height	37 mm	1.5"		
Q	Machine upper width**	3145 mm	10'4"		
R	Distance, swing center to rear end	3605 mm	11'10"		

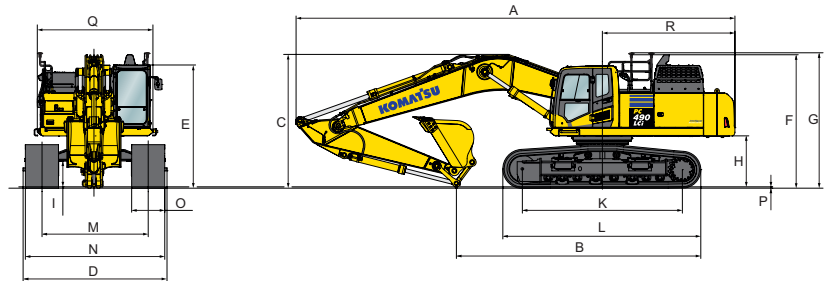
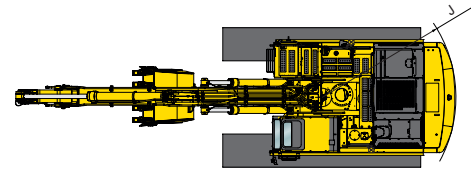

* : Including grouser height ** : Including handrail



BACKHOE BUCKET, ARM AND BOOM COMBINATION

Bucket Type	Bucket										
	Capacity	Teeth	Width		Weight		Tip Radius	3.4 m (11'1")	4.0 m (13'1")		
Komatsu TL	1.12 m ³	1.47 yd ³	3	762 mm	30"	1287 kg	2838 lb	1826 mm	72"	●	●
	1.35 m ³	1.76 yd ³	4	914 mm	36"	1441 kg	3176 lb	1826 mm	72"	●	●
	1.64 m ³	2.15 yd ³	4	1067 mm	42"	1561 kg	3442 lb	1826 mm	72"	●	●
	1.94 m ³	2.54 yd ³	5	1219 mm	48"	1714 kg	3779 lb	1826 mm	72"	●	○
	2.25 m ³	2.94 yd ³	6	1372 mm	54"	1867 kg	4117 lb	1826 mm	72"	●	○
	2.55 m ³	3.34 yd ³	6	1524 mm	60"	1988 kg	4382 lb	1826 mm	72"	○	□
	2.87 m ³	3.75 yd ³	7	1676 mm	66"	2141 kg	4720 lb	1826 mm	72"	□	⊙
Komatsu HP	3.17 m ³	4.15 yd ³	7	1829 mm	72"	2261 kg	4985 lb	1826 mm	72"	⊙	⊙
	1.12 m ³	1.47 yd ³	3	762 mm	30"	1508 kg	3324 lb	1826 mm	72"	●	●
	1.35 m ³	1.76 yd ³	4	914 mm	36"	1663 kg	3667 lb	1826 mm	72"	●	●
	1.64 m ³	2.15 yd ³	4	1067 mm	42"	1835 kg	4046 lb	1826 mm	72"	●	●
	1.94 m ³	2.54 yd ³	5	1219 mm	48"	1978 kg	4360 lb	1826 mm	72"	●	●
	2.25 m ³	2.94 yd ³	6	1372 mm	54"	2151 kg	4741 lb	1826 mm	72"	○	□
	2.55 m ³	3.34 yd ³	6	1524 mm	60"	2293 kg	5056 lb	1826 mm	72"	□	□
Komatsu HPS	2.87 m ³	3.75 yd ³	7	1676 mm	66"	2466 kg	5437 lb	1826 mm	72"	⊙	⊙
	3.17 m ³	4.15 yd ³	7	1829 mm	72"	2609 kg	5752 lb	1826 mm	72"	⊙	X
	1.12 m ³	1.47 yd ³	3	762 mm	30"	1632 kg	3597 lb	1826 mm	72"	●	●
	1.35 m ³	1.76 yd ³	4	914 mm	36"	1806 kg	3981 lb	1826 mm	72"	●	●
	1.64 m ³	2.15 yd ³	4	1067 mm	42"	2003 kg	4416 lb	1826 mm	72"	●	●
Komatsu HPX	1.94 m ³	2.54 yd ³	5	1219 mm	48"	2172 kg	4789 lb	1826 mm	72"	●	○
	2.25 m ³	2.94 yd ³	6	1372 mm	54"	2371 kg	5228 lb	1826 mm	72"	○	□
	2.55 m ³	3.34 yd ³	6	1524 mm	60"	2540 kg	5600 lb	1826 mm	72"	□	⊙
	2.87 m ³	3.75 yd ³	7	1676 mm	66"	2739 kg	6039 lb	1826 mm	72"	⊙	X
	1.12 m ³	1.47 yd ³	3	762 mm	30"	1759 kg	3877 lb	1826 mm	72"	●	●
Komatsu HPX	1.35 m ³	1.76 yd ³	4	914 mm	36"	1933 kg	4261 lb	1826 mm	72"	●	●
	1.64 m ³	2.15 yd ³	4	1067 mm	42"	2130 kg	4696 lb	1826 mm	72"	●	●
	1.94 m ³	2.54 yd ³	5	1219 mm	48"	2299 kg	5069 lb	1826 mm	72"	●	○
	2.25 m ³	2.94 yd ³	6	1372 mm	54"	2498 kg	5508 lb	1826 mm	72"	○	□
	2.55 m ³	3.34 yd ³	6	1524 mm	60"	2667 kg	5880 lb	1826 mm	72"	□	⊙
2.87 m ³	3.75 yd ³	7	1676 mm	66"	2866 kg	6319 lb	1826 mm	72"	⊙	X	

For best semi-automatic machine control performance, observe maximum attachment weights:

- 3350 kg **7,385 lb** maximum for 3380 mm 11' 1" standard arm assembly
- 3200 kg **7,054 lb** maximum for 4000 mm 13' 1" standard arm assembly

Exceeding recommended attachment weights may negatively impact performance and accuracy of semi-automatic function.

- - Used with material weights up to 3,500 lb/yd³ - Quarry/rock/high abrasion applications
- - Used with material weights up to 3,000 lb/yd³ - Tough digging applications
- - Used with material weights up to 2,500 lb/yd³ - General construction
- ⊙ - Used with material weights up to 2,000 lb/yd³ - Light materials applications
- X - Not useable

SPECIFICATIONS



WORKING RANGE

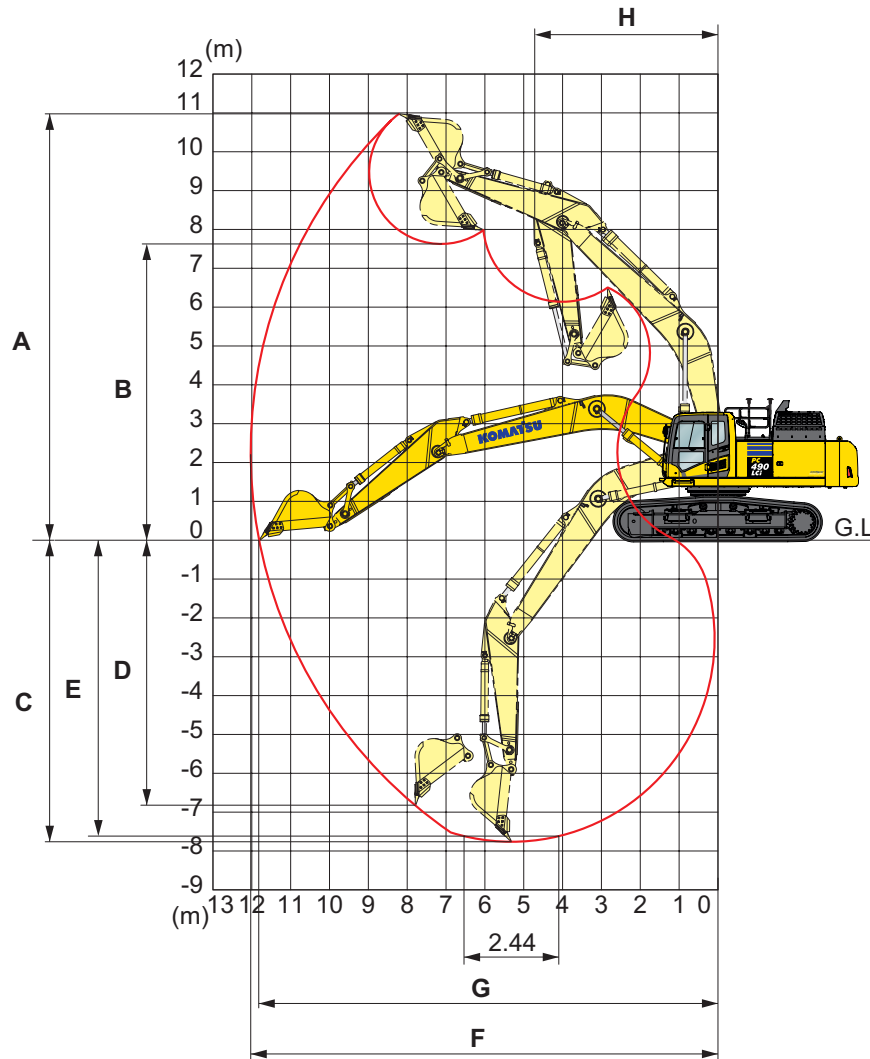

	Arm Length	3380 mm 11'1"	4000 mm 13'1"
A	Max. digging height	10980 mm 36'0"	11090 mm 36'5"
B	Max. dumping height	7630 mm 25'0"	7780 mm 25'6"
C	Max. digging depth	7755 mm 25'5"	8380 mm 27'6"
D	Max. vertical wall digging depth	6805 mm 22'4"	7220 mm 23'8"
E	Max. digging depth for 8' level bottom	7615 mm 25'0"	8250 mm 27'0"
F	Max. digging reach	12030 mm 39'6"	12565 mm 41'3"
G	Max. digging reach at ground level	11810 mm 38'9"	12365 mm 40'7"
H	Min. swing radius	4735 mm 15'6"	4800 mm 15'9"
SAE rating	Bucket digging force at power max.	239 kN 24,400 kg / 53,790 lb	239 kN 24,400 kg / 53,790 lb
	Arm crowd force at power max.	205 kN 20900 kg / 46,080 lb	184 kN 18800 kg / 41,450 lb
ISO rating	Bucket digging force at power max.	275 kN 28000 kg / 61,730 lb	275 kN 28000 kg / 61,730 lb
	Arm crowd force at power max.	214 kN 21800 kg / 48,060 lb	190 kN 19400 kg / 42,770 lb

PC490LCI-11

LIFT CAPACITIES

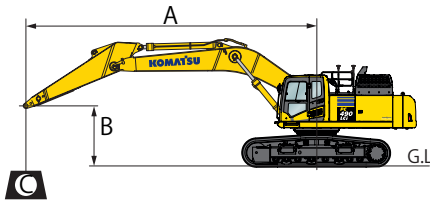

- A: Reach from swing center
- B: Bucket hook height
- C: Lifting capacity
- Cf: Rating over front
- Cs: Rating over side
- ⊗: Rating at maximum reach

- Conditions:
- Boom length: 7060 mm 23' 2"
 - Bucket: None
 - Undercarriage: Fixed Gauge
 - Lifting mode: On

Arm: 3380 mm 11'1"		Bucket: None				Shoes: 900 mm 35.5" triple grouser				Unit: kg lb			
B	A	3.0 m 10'		4.6 m 15'		6.1 m 20'		7.6 m 25'		9.1 m 30'		⊗ MAX	
	MAX	Cf	Cs	Cf	Cs	Cf	Cs	Cf	Cs	Cf	Cs	Cf	Cs
9.1 m 30'	7.5 m 24'											* 9700	* 9700
												* 21300	* 21300
7.6 m 25'	8.6 m 28'							* 11720	11460			* 9200	9200
								* 25800	25200			* 20200	20200
6.1 m 20'	9.4 m 31'							* 12230	11270	* 11430	8590	* 9070	8190
								* 26900	24800	* 25200	18900	* 20000	18000
4.6 m 15'	9.9 m 33'			* 20080	* 20080	* 15510	15000	* 13160	10950	* 11770	8460	* 9210	7500
				* 44200	* 44200	* 34200	33000	* 29000	24100	* 25900	18600	* 20300	16500
3.0 m 10'	10.1 m 33'			* 24120	21240	* 17470	14300	* 14190	10590	* 12260	8270	* 9580	7150
				* 53100	46800	* 38500	31500	* 31200	23300	* 27000	18200	* 21100	15700
1.5 m 5'	10.1 m 33'			* 19210	* 19210	* 18890	13740	* 15020	10270	12460	8090	* 10240	7050
				* 42300	* 42300	* 41600	30300	* 33100	22600	27400	17800	* 22500	15500
0 m 0'	9.9 m 33'			* 21790	20000	* 19390	13410	* 15390	10040	12320	7970	* 11050	7190
				* 48000	44100	* 42700	29500	* 33900	22100	27100	17500	* 24300	15800
-1.5 m -5'	9.4 m 31'	* 15850	* 15850	* 24430	19990	* 18910	13290	* 15080	9940	* 12170	7930	* 11600	7640
		* 34900	* 34900	* 53800	44000	* 41600	29300	* 33200	21900	* 26800	17400	* 25500	16800
-3.0 m -10'	8.7 m 28'	* 24660	* 24660	* 21940	20160	* 17370	13340	* 13810	9980			* 11490	8560
		* 54300	* 54300	* 48300	44400	* 38300	29400	* 30400	22000			* 25300	18800
-4.6 m -15'	7.5 m 25'	* 21900	* 21900	* 17970	* 17970	* 14350	13570					* 10930	10450
		* 48200	* 48200	* 39600	* 39600	* 31600	29900					* 24100	23000

Arm: 4000 mm 13'1"		Bucket: None				Shoes: 900 mm 35.5" triple grouser				Unit: kg lb			
B	A	3.0 m 10'		4.6 m 15'		6.1 m 20'		7.6 m 25'		9.1 m 30'		⊗ MAX	
	MAX	Cf	Cs	Cf	Cs	Cf	Cs	Cf	Cs	Cf	Cs	Cf	Cs
9.1 m 30'	8.2 m 27'											* 8240	* 8240
												* 18100	* 18100
7.6 m 25'	9.3 m 30'									* 8750	8670	* 7890	* 7890
										* 19200	19100	* 17400	* 17400
6.1 m 20'	10.0 m 33'							* 11350	11330	* 10650	8610	* 7810	7470
								* 25000	24900	* 23400	18900	* 17200	16400
4.6 m 15'	10.5 m 34'					* 14350	* 14350	* 12350	10980	* 11120	8440	* 7930	6890
						* 31600	* 31600	* 27200	24200	* 24500	18600	* 17400	15100
3.0 m 10'	10.7 m 35'			* 22270	21570	* 16440	14370	* 13480	10570	* 11710	8210	* 8230	6570
				* 49100	47500	* 36200	31600	* 29700	23300	* 25800	18100	* 18100	14400
1.5 m 5'	10.7 m 35'			* 25080	20330	* 18130	13700	* 14470	10190	* 12240	7990	* 8760	6470
				* 55300	44800	* 39900	30200	* 31900	22400	* 26900	17600	* 19300	14200
0 m 0'	10.5 m 34'			* 23770	19770	* 19010	13260	* 15050	9900	12190	7820	* 9590	6570
				* 52400	43500	* 41900	29200	* 33100	21800	26800	17200	* 21100	14400
-1.5 m -5'	10.0 m 33'	* 15460	* 15460	* 25010	19610	* 18940	13050	* 15040	9740	12090	7730	10720	6920
		* 34100	* 34100	* 55100	43200	* 41700	28700	* 33100	21400	26600	17000	23600	15200
-3.0 m -10'	9.3 m 30'	* 22240	* 22240	* 23040	19700	* 17870	13040	* 14220	9720	* 11220	7760	* 10930	7640
		* 49000	* 49000	* 50800	43400	* 39400	28700	* 31300	21400	* 24700	17100	* 24100	16800
-4.6 m -15'	8.2 m 27'	* 25460	* 25460	* 19730	* 19730	* 15550	13200	* 12100	9870			* 10700	9040
		* 56100	* 56100	* 43500	* 43500	* 34200	29100	* 26600	21700			* 23600	19900
-6.1 m -20'	6.6 m 22'			* 14280	* 14280	* 10970	10970					* 9670	* 9670
				* 31400	* 31400	* 24100	24100					* 21300	21300

*Load is limited by hydraulic capacity rather than tipping. Ratings are based on ISO standard No. 10567. Rated loads do not exceed 87% of hydraulic lift capacity or 75% of tipping load.



STANDARD EQUIPMENT

- 3 speed travel with auto shift
- Alternator, 90 Ampere, 24V
- AM/FM radio
- Arm holding valve
- Automatic engine warm-up system
- Automatic climate control/air conditioner/heater/defroster
- Auto idle
- Auto idle shut down, programmable
- Auxiliary input (3.5mm jack)
- Batteries, large capacity (2 x 12V)
- Battery master disconnect switch
- Boom holding valves
- Carrier rollers, (2 each side)
- Converter, (2) x 12V
- Counterweight, 9573 kg **21,105 lb**
- Dry type air cleaner, double element
- Electric horn
- Engine, Komatsu SAA6D125E-7
- Engine coolant to -25°C **-13°F**
- EMMS monitoring system
- Engine overheat prevention system
- Extended work equipment grease interval
- Fan guard structure
- Fuel priming pump, 24V
- Fuel system pre-filter 10 micron
- Grease sealed track chain
- High back air suspension seat, with heat
- Hydraulic cooling fan (reversible)
- Hydraulic track adjusters
- KOMTRAX® Level 5.0
- Large LCD color monitor, high resolution
- Lock lever
- Mirrors, (LH and RH)
- Operator Protective Top Guard (OPG), Level 1
- Operator identification system
- Pattern change valve (ISO to BH control)
- Power maximizing system
- PPC hydraulic control system
- Pump/engine room partition cover
- Radiator and oil cooler dustproof net
- Rear reflectors
- Rearview monitoring system (1 camera)
- Revolving frame deck guard
- Revolving frame undercovers
- ROPS cab (ISO12117-2)
- Seat belt indicator
- Seat belt, retractable, 76mm **3"**
- Secondary engine shutoff switch
- Service valve
- Skylight
- Slip resistant foot plates
- Starter motor, 11.0kW/24V x 1
- Suction fan
- Thermal and fan guards
- Track frame swivel guard
- Track roller guards, center section
- Track rollers, 8 (each side)
- Track shoes, triple grouser, 700mm **28"**
- Travel alarm
- Two boom mode settings
- Working lights, 2 (boom and RH front)
- Working mode selection system



OPTIONAL EQUIPMENT

- Arms
 - 3380 mm **11'1"** arm assembly
 - 3380 mm **11'1"** arm assembly with piping
 - 4000 mm **13'1"** arm assembly
- Booms
 - 7000 mm **23'2"** HD boom assembly
 - 7000 mm **23'2"** HD boom assembly with piping
- Cab guards
 - Lower front window guard
 - Full front guard, OPG Level 1
 - Full front guard, OPG Level 2
 - Bolt-on top guard, OPG Level 2
- Counterweight removal system
- High altitude arrangement
- High pressure in-line hydraulic filters
- Hydraulic control unit, 1 actuator
- Rain visor
- Revolving frame undercovers, heavy duty
- Revolving frame undercovers, severe duty
- Sun visor
- Straight travel pedal
- Track roller guards, full length
- Track shoes, triple grouser, 800 mm **31.5"**
- Track shoes, triple grouser, 900 mm **35.5"**
- Working lights, front, two additional cab mounted



ATTACHMENT OPTIONS

- Hydraulic couplers
- Hydraulic kits, field installed
- Load hold, anti-burst valves

For a complete list of available attachments, please contact your local Komatsu distributor.

KOMATSU®

Note: All comparisons and claims of improved performance made herein are made with respect to the prior Komatsu model unless otherwise specifically stated.