

# KOMATSU®

# PC238USLC-11

Tier 4 Final Engine

## HYDRAULIC EXCAVATOR



Photos may include optional equipment.

### NET HORSEPOWER

165 HP @ 2000 rpm  
123 kW @ 2000 rpm

### OPERATING WEIGHT

54,230-55,660 lb  
24600 - 25250 kg

### BUCKET CAPACITY

0.66-1.57 yd<sup>3</sup>  
0.50-1.20 m<sup>3</sup>

# PC238USLC

# WALK-AROUND

PC238USLG-11



Photos may include optional equipment.

## NET HORSEPOWER

165 HP @ 2000 rpm  
123 kW @ 2000 rpm

## OPERATING WEIGHT

54,230-55,660 lb  
24600 - 25250 kg

## BUCKET CAPACITY

0.66-1.57 yd<sup>3</sup>  
0.50-1.20 m<sup>3</sup>



## CONVENTIONAL PERFORMANCE IN A TIGHT TAIL BODY

Heavy counterweight mass provides equal or better lift capacity than most conventional excavators in the same size class.

Rounded cab profile with a sliding door, allows the cab to swing within the same swing radius as the counterweight for true tight tail performance.



A powerful **Komatsu SAA6D107E-3 engine** provides a net output of 123 kW **165 HP**. This engine is EPA Tier 4 Final emissions certified.

**Variable Geometry Turbocharger** improves engine response and provides optimum air flow under all speed and load conditions.

**Komatsu Diesel Particulate Filter (KDPF) and Selective Catalytic Reduction (SCR) system** reduces particulate matter and NOx, while providing automatic regeneration that does not interfere with daily operation.

**Komatsu Auto Idle Shutdown** helps reduce nonproductive engine idle time and reduces operating costs.

**Komatsu's Closed-Center Load Sensing System (CLSS)** provides quick response and smooth operation to maximize productivity.

**Enhanced working modes** are designed to match engine speed, pump delivery, and system pressure to the application.

**Temperature controlled fan clutch** helps improve fuel efficiency and lower sound levels.

### Large LCD color monitor panel:

- 7" high resolution screen
- Provides "Ecology-Guidance" for fuel efficient operation
- Enhanced attachment control

### Aux jack and (2) 12V outlets

### Rearview monitoring system (standard)

**Equipment Management Monitoring System (EMMS)** continuously monitors machine operation and vital systems to identify machine issues and assist with troubleshooting.

### Enhanced working environment

- Integrated ROPS cab design (ISO 12117-2)
- Cab meets ISO Level 1 Operator Protective Guard (OPG) top guard (ISO 10262)

**Wide access service doors** provide easy access for ground level maintenance.

### Komatsu designed and manufactured components

**New engine and hydraulic control technology** improves operational efficiency and increases productivity up to four percent.

**Operator identification system** can track machine performance for up to 100 operators.

**Handrails (standard)** provide convenient access to the upper structure.

**Battery disconnect switch** allows a technician to disconnect the power supply before servicing the machine.

The **KOMTRAX®** telematics system is standard on Komatsu equipment with no subscription fees for the life of the machine. Using the latest wireless technology, **KOMTRAX®** transmits valuable information, such as location, utilization, and maintenance records to a PC or smartphone app. Custom machine reports are provided for identifying machine efficiency and operating trends. **KOMTRAX®** also provides advanced machine troubleshooting capabilities by continuously monitoring machine health.

# PERFORMANCE FEATURES

## KOMATSU NEW ENGINE TECHNOLOGIES

### Komatsu's New Emission Regulations-compliant Engine

New regulations effective in 2014 require the reduction of NOx emissions to one tenth or below from the preceding regulations. In addition to refining the Tier 4 Interim technologies, Komatsu has developed a new Selective Catalytic Reduction (SCR) device in-house.

### Technologies Applied to New Engine

#### Heavy-duty aftertreatment system

This new system combines a Komatsu Diesel Particulate Filter (KDPF) and SCR. The SCR NOx reduction system injects the correct amount of Diesel Exhaust Fluid (DEF) at the proper rate, thereby decomposing NOx into non-toxic water (H<sub>2</sub>O) and nitrogen gas (N<sub>2</sub>).

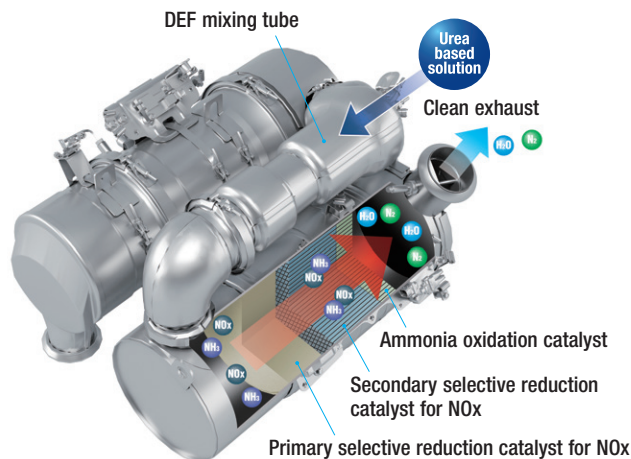

#### Variable Geometry Turbocharger (VGT) system

The VGT system features Komatsu design hydraulic technology for variable control of air-flow and supplies optimal air according to load conditions. The upgraded version realizes better exhaust temperature management.

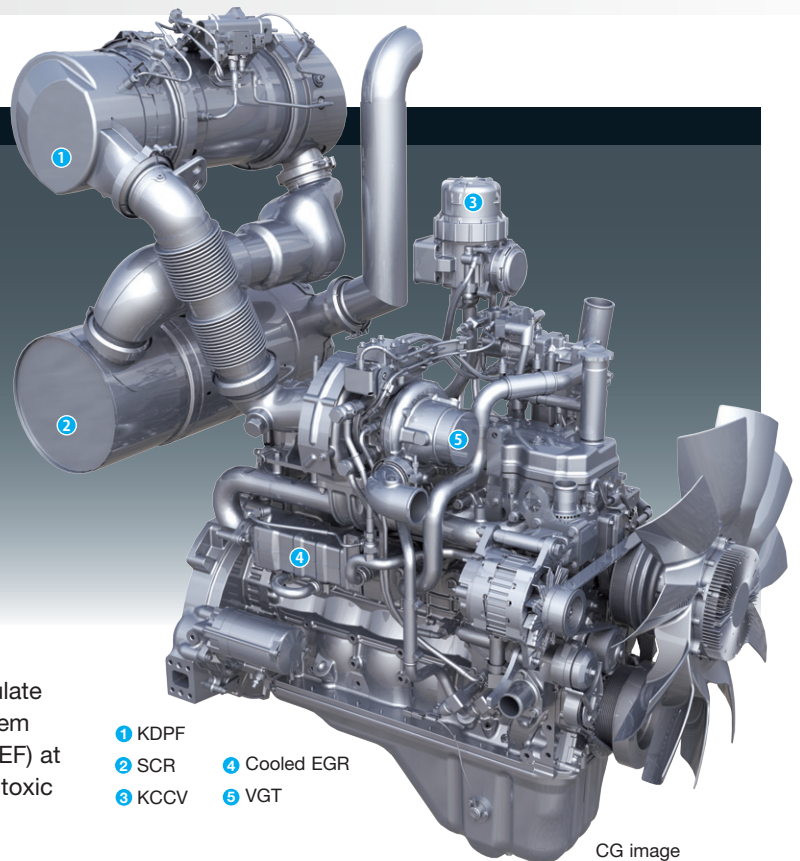
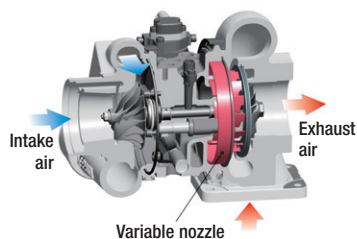

CG image

- 1 KDPF
- 2 SCR
- 3 KCCV
- 4 Cooled EGR
- 5 VGT

#### Heavy-duty cooled Exhaust Gas Recirculation (EGR) system

The system recirculates a portion of exhaust gas into air intake and lowers combustion temperatures to reduce NOx emissions. Furthermore, while EGR gas flow is increased, by incorporating a high-efficiency and compactly designed cooling system, the system achieves a dynamic reduction of NOx, while helping reduce fuel consumption.

#### Advanced Electronic control system

The electronic control system performs high-speed processing of all signals from sensors installed in the machine providing total control of equipment in all operating conditions of use. Engine condition information is displayed via an onboard network to the monitor inside the cab, providing necessary information to the operator. Additionally, managing the information via KOMTRAX helps customers keep up with required maintenance.

#### High Pressure Common Rail (HPCR) fuel injection system

High pressure fuel injection with computerized control attains close-to-complete combustion, reducing Particulate Matter (PM) emissions. While this technology is already used in current engines, the new system uses a higher-pressure injection, thereby reducing both PM emissions and fuel consumption at all engine load conditions.

## Enhanced Productivity

The PC238USLC-11's P mode provides improved performance in demanding applications.

**Productivity** Compared to the PC228USLC-10 in P mode

**Up to 4% increase**

P mode (90° swing truck loading)

## Large Digging Force

With the one-touch Power Max function, digging force has been further increased. (8.5 seconds of operation)

### Maximum arm crowd force (ISO):

101 kN (10.3 t) ➔ **108 kN (11.0 t) 7 % UP**  
(With Power Max.)

### Maximum bucket digging force (ISO):

138 kN (14.1 t) ➔ **149 kN (15.2 t) 8 % UP**  
(With Power Max.)

Measured with Power Max function, 2925 mm arm and ISO 6015 rating

## Efficient Hydraulic System

The PC238USLC-11 uses a Closed-Center Load Sensing System (CLSS) that improves fuel efficiency and provides quick response to the operator's demands. The control system matches engine and hydraulic demand at the most efficient point under any load condition. There have also been improvements in the main valve and hydraulic circuit to reduce hydraulic loss, resulting in higher efficiency and lower fuel consumption.

## Working Mode Selection

The PC238USLC-11 excavator is equipped with six working modes (P, E, L, B, ATT/P and ATT/E). Each mode is designed to match engine speed, pump flow, and system pressure to the application. The PC238USLC-11 features an attachment mode (ATT/E) that allows operators to run attachments while in Economy mode.

Working Mode	Application	Advantage
P	Power mode	<ul style="list-style-type: none"> <li>•Maximum production/power</li> <li>•Fast cycle times</li> </ul>
E	Economy mode	<ul style="list-style-type: none"> <li>•Good cycle times</li> <li>•Better fuel economy</li> </ul>
L	Lifting mode	<ul style="list-style-type: none"> <li>•Increases hydraulic pressure</li> </ul>
B	Breaker mode	<ul style="list-style-type: none"> <li>•Optimum engine rpm, hydraulic flow</li> </ul>
ATT/P	Attachment Power mode	<ul style="list-style-type: none"> <li>•Optimum engine rpm, hydraulic flow, 2-way</li> <li>•Power mode</li> </ul>
ATT/E	Attachment Economy mode	<ul style="list-style-type: none"> <li>•Optimum engine rpm, hydraulic flow, 2-way</li> <li>•Economy mode</li> </ul>

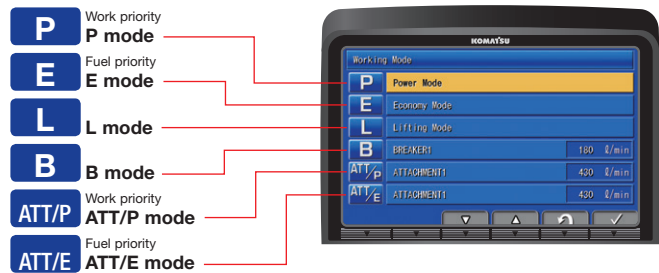

## Arm Quick Return Valve

When the arm is extended, the quick return valve directs additional oil through a second line directly back to tank which reduces back pressure. Reduces fuel consumption and improves efficiency.



# PERFORMANCE FEATURES

PC238USLC-11



## Viscous Fan Clutch

A temperature controlled viscous fan clutch improves engine efficiency and reduces engine power requirements when operating in cooler temperatures.

## Komatsu Auto Idle Shutdown

Komatsu auto idle shutdown automatically shuts the engine down after idling for a set period of time to reduce unnecessary fuel consumption and exhaust emissions. The countdown to engine shutdown can be easily programmed from five to 60 minutes.

## Fine Controllability

Proportional Pilot Controls (PPC) allow the operator finite control and feedback with minimal effort for comfort and efficiency.

## Stable Platform

The PC238USLC-11's compact 6.7 mt **14,815 lb** counterweight provides exceptional lifting capacity and minimizes rear swing radius for operation in confined areas.

## Pattern Change Valve (Standard)

A pattern change valve is conveniently located at the front of the machine, making switching from excavator controls to backhoe controls quick and easy.

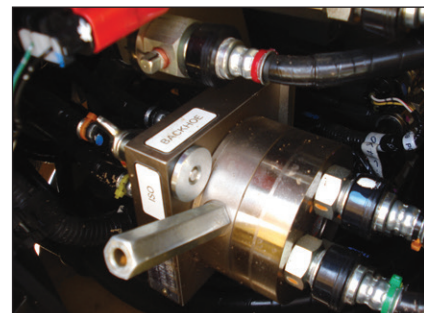

# OPERATION FEATURES

## SHORT SWING RADIUS

### Ideal for Confined Applications

The PC238USLC-11 is an ideal machine for applications such as road work, underground utilities or other applications where a conventional excavator will not fit. The contoured cab design and convex sliding door allow the cab to swing within the same radius as the counterweight. Trucks can be positioned closer to the machine when working within one lane of traffic, improving operator confidence and job efficiency.

### Short Implement Swing Radius

A higher boom raise angle than a standard excavator reduces the minimum front implement swing radius down to 2310 mm 7' 7". The result is greater front swing clearance when space is limited.

### Short Tail Swing Radius

1810 mm 5' 11" short tail swing radius of the PC238USLC-11 allows the machine to work in more confined areas than a conventional machine.



**220 mm**  
**9"**

Protrusion from the track (Rear)

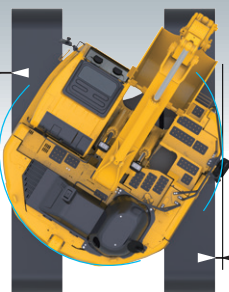

**144 mm**  
**6"**

Protrusion from the track (Step)

**208 mm** **8"**  
(Mirror)

**200 mm**  
**8"**

Protrusion from the track (Handrail)

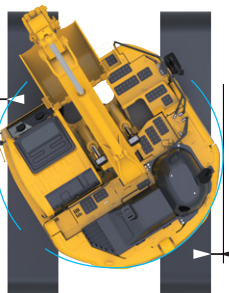

**220 mm**  
**9"**

Protrusion from the track

**350 mm** **14"**  
(Mirror)

## Greater Working Ranges

Raising the boom on the PC238USLC-11 to a greater angle enhances overall working performance. Job sites that require a taller upper reach, such as demolition and slope cutting, also benefit from the increased digging and dumping ranges of the PC238USLC-11.

## Working range

Max. digging height

**10700 mm**  
**35' 1"**

Max. digging depth

**6620 mm**  
**21' 9"**

Max. digging reach

**9875 mm**  
**32' 5"**

# OPERATION FEATURES

## ROPS CAB STRUCTURE

### ROPS Cab (ISO 12117-2)

The machine is equipped with a ROPS cab that conforms to ISO 12117-2 for excavators as standard equipment. The ROPS cab has high shock absorption performance, featuring excellent durability and impact strength. It also satisfies the requirements for Level 1 Operator Protective Guard (OPG) and top guard (ISO 10262).



## Rear View Monitoring System

An updated rear view monitoring system display has a camera image that is continuously displayed together with the gauges and important vehicle information. This enables the operator to carry out work while easily checking the surrounding area.



## Low Vibration with Viscous Cab Mounts

The PC238USLC-11 uses viscous mounts for the cab that incorporate a longer stroke and the addition of a spring. The cab damper mounting combined with a high rigidity deck reduces vibration at the operator's seat.

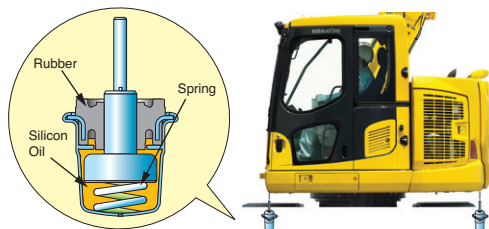

## General Features

- Lock lever
- Seat belt, retractable
- Tempered and tinted glass
- Large mirrors
- Slip-resistant plates
- Thermal and fan guards
- Pump/engine compartment partition
- Travel alarm
- Large cab entrance step
- Handrails
- Sliding door

**Secondary engine shut down switch** at base of seat to shutdown the engine.





# WORKING ENVIRONMENT

## Comfortable Working Space

### Large cab with wide front view and foot space

A large operator cab with rounded corner provides an overall cab size similar to a standard excavator cab even though this machine has an extra small swing radius. A sliding door enables easy access especially in confined work areas. Additional operator comfort is provided with a fully adjustable suspension seat.



### Automatic Air Conditioner

The automatic air conditioner allows the operator to easily and precisely set the cab atmosphere using the large LCD color monitor panel. The bi-level control function improves air flow and keeps the inside of the cab comfortable throughout the year.



### Auxiliary input jack

Connecting an auxiliary device such as an MP3 player to the auxiliary input enables the operator to hear through the stereo speakers installed in the cab.



## Standard Equipment

Automatic air conditioner (A/C)

Pull-up front window



Remote intermittent wiper with windshield washer



Cab light

Opening & closing skylight



Defroster (conforms to the ISO standard)



Windshield glass with excellent UV filtering

AM/FM radio



Cup holder



Literature box



Cigarette lighter & 12 V power supply



# WORKING ENVIRONMENT

## LARGE HIGH RESOLUTION LIQUID CRYSTAL DISPLAY (LCD) MONITOR



### New Monitor Panel Interface Design

An updated, large, high-resolution LCD color monitor enables accurate and smooth work. The redesigned interface displays key machine information in the new, user-friendly interface. A rear view camera and a DEF level gauge display now appear on the default main screen. The interface has a function that enables the main screen mode to be changed to provide the optimum screen information for the operator.

#### Indicators

- |                                    |                             |
|------------------------------------|-----------------------------|
| 1 Auto-decelerator                 | 8 Fuel gauge                |
| 2 Working mode                     | 9 DEF level gauge           |
| 3 Travel speed                     | 10 Service meter, clock     |
| 4 Ecology gauge                    | 11 Fuel consumption gauge   |
| 5 Camera display                   | 12 Guidance icon            |
| 6 Engine coolant temperature gauge | 13 Function switches        |
| 7 Hydraulic oil temperature gauge  | 14 Camera direction display |
|                                    | 15 DEF level caution lamp   |

#### Basic operation switches

- |                         |                         |
|-------------------------|-------------------------|
| 1 Auto-decelerator      | 4 Buzzer cancel         |
| 2 Working mode selector | 5 Wiper                 |
| 3 Travel speed selector | 6 Window washer         |
|                         | 7 Auto climate controls |

### Switchable display modes

The updated monitor screen display mode can be easily switched by pressing the F3 key.

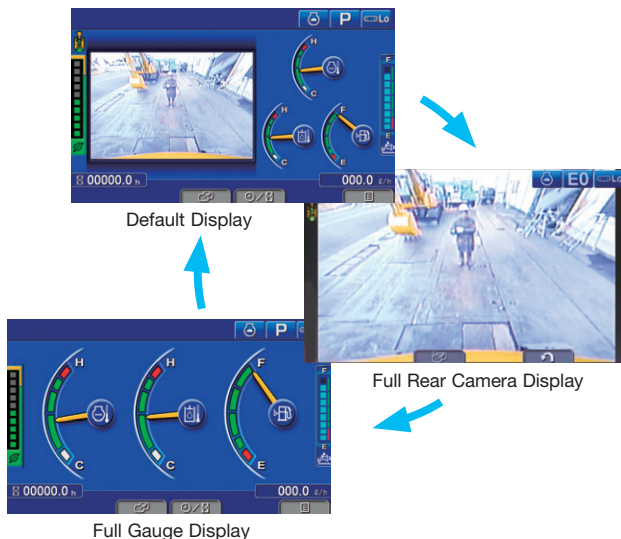

### Visual user menu

Pressing the F6 key on the main screen displays the user menu screen. The menus are grouped for each function, and use easy-to-understand icons which enable the machine to be operated easily.



- 1 Energy saving guidance
- 2 Machine settings
- 3 Aftertreatment device regeneration\*
- 4 SCR information
- 5 Maintenance
- 6 Monitor setting
- 7 Message check

### Operator Identification Function

An operator identification (ID) code can be set for each operator and used to manage operation information of individual machines using KOMTRAX data. Data sent from KOMTRAX can be used to analyze operation status by operator, application, as well as by machine.



### Support Efficiency Improvement

#### Ecology guidance

While the machine is operating, ecology guidance information can be displayed on the monitor screen to provide fuel saving advice in real time.

#### Ecology gauge & fuel consumption gauge

The monitor screen includes an ecology gauge and a fuel consumption gauge which is displayed continuously. The operator can set a target value.



Ecology gauge      Fuel consumption gauge  
Ecology guidance

### Operation records, fuel consumption history, and Ecology guidance records

The ecology guidance menu enables the operator to check the operation records, fuel consumption history and ecology guidance records.

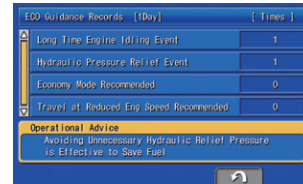

Ecology guidance record

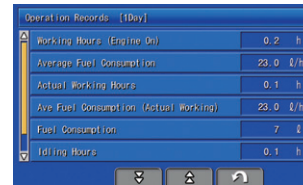

Operation record



Fuel consumption history

### KomVision (Optional)

An optional three camera system provides a bird's eye view (including cab visibility) of the machine and surrounding area. This system improves operation and situational awareness on the jobsite

KomVision benefits operators working in urban environments, confined spaces, and high traffic jobsites from increased visibility and situational awareness.



Distance markers are displayed in the monitor to show machine tail swing radius.

# MAINTENANCE FEATURES

## Standard high-efficiency fuel filter and fuel pre-filter with water separator

A high-efficiency fuel filter and a pre-filter with water separator increase reliability. The fuel pre-filter is also equipped with a priming pump.

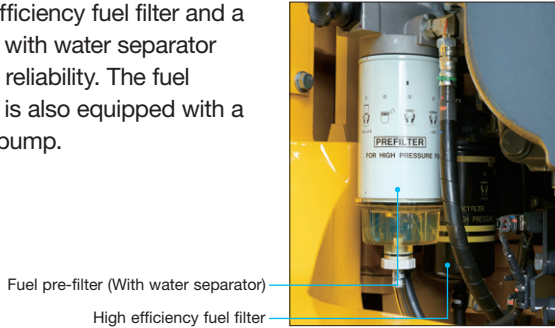

Fuel pre-filter (With water separator)  
High efficiency fuel filter

## Easy access to engine oil filter, engine main fuel filter and fuel drain valve

Engine oil filter, engine main fuel filter and fuel drain valve are remote mounted to improve accessibility.

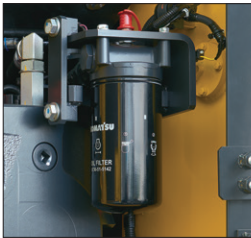

Engine oil filter

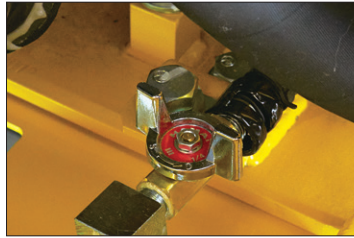

Fuel drain valve

## Fan belt auto-tensioner

For free maintenance of fan belt tension adjustment.

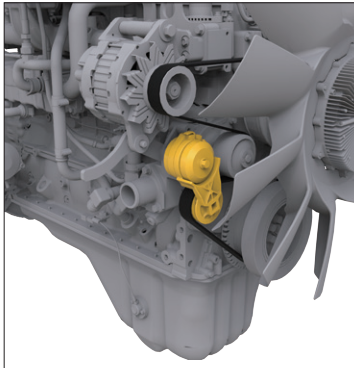

## Battery disconnect switch

A standard battery disconnect switch allows a technician to disconnect the power supply and lock out before servicing the machine.



## Side-by-side cooling

Since radiator, aftercooler and oil cooler are arranged in parallel, it is easy to clean, remove and install them. Radiator, aftercooler, and oil cooler made of aluminum have high cooling efficiency and are easily recycled.

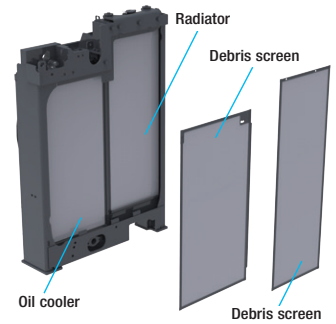

## A/C filter

The A/C filter is removed and installed without the use of tools, facilitating filter maintenance.

## Washable cab floor mat

The PC238USLC-11's floor is easy to keep clean. The gently inclined surface has a flanged floor mat and drainage holes to facilitate run off.



## DEF tank

The DEF tank is installed on the right front platform for easy access. The DEF tank includes a sight glass and fold down shelf to support a DEF container during filling. A separated pump also provides excellent serviceability.



## Long-life oil, filter

Engine oil & engine oil filter	every <b>500</b> hours
Hydraulic oil	every <b>5000</b> hours
Hydraulic oil filter	every <b>1000</b> hours

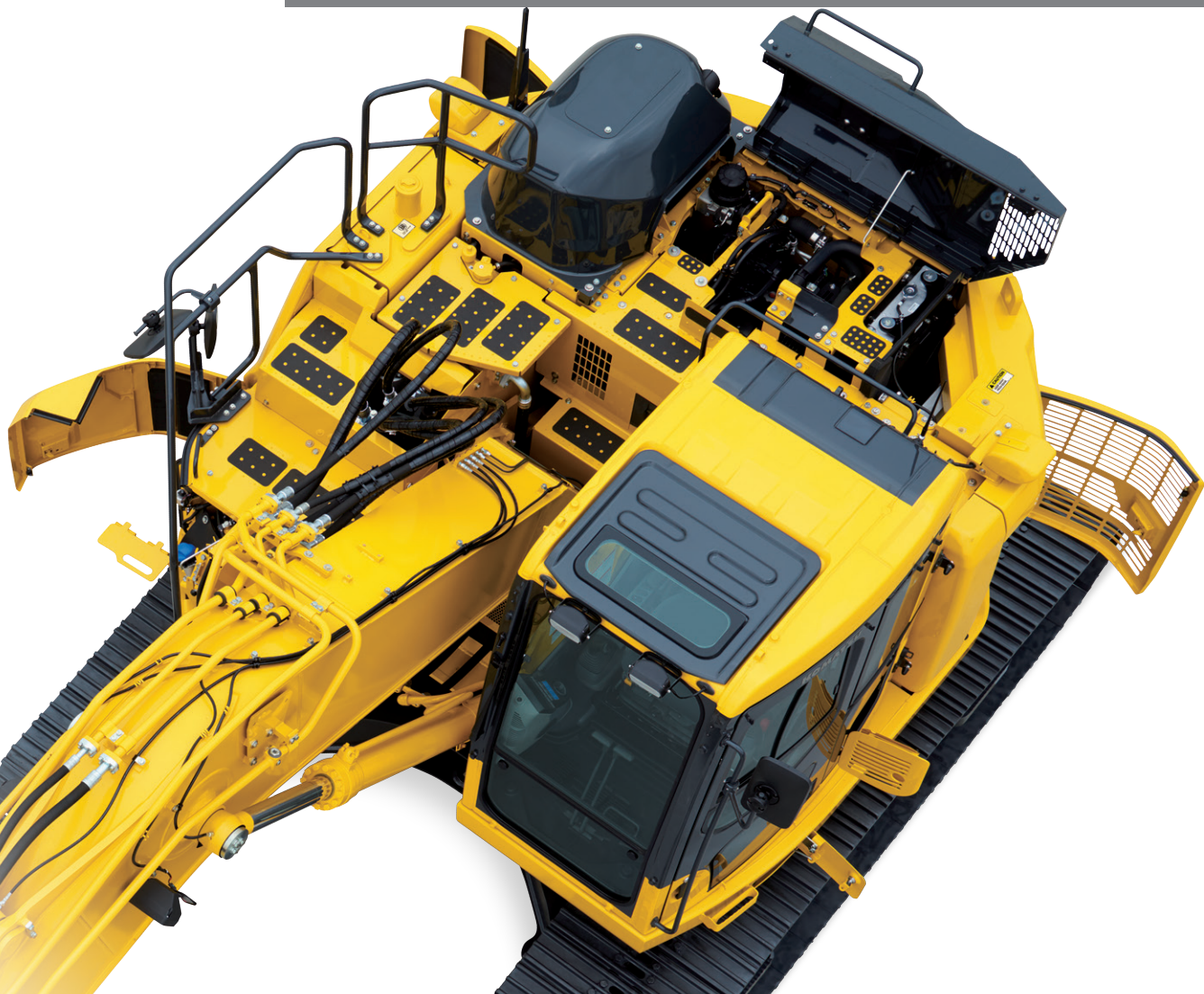

### Maintenance Information

#### Supports the DEF level and refill timing

The DEF level gauge is displayed continuously on the right side of the monitor screen. In addition, when the refill timing\* is reached, the DEF low level guidance appears as a pop-up display to inform the operator in real time.

\* In Tier 4 Final emissions certified, the engine output must be restricted at shortage of DEF.



DEF low level guidance      DEF level gauge

#### “Maintenance time caution lamp” display

When the remaining time to maintenance becomes less than 30 hours\*, the maintenance time monitor appears. Pressing the F6 key switches the monitor to the maintenance screen.

\* The setting can be changed within the range between 10 and 200 hours.

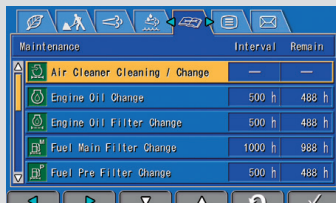

Maintenance screen

#### Aftertreatment devices regeneration automatic display

When it is necessary to carry out manual regeneration (The manual stationary regeneration) of the KDPF, the display automatically switches to the aftertreatment device regeneration screen to inform the operator.

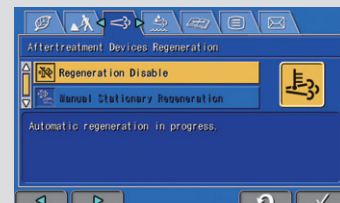

Aftertreatment device regeneration screen

# KOMATSU PARTS & SERVICE SUPPORT



## KOMATSU CARE

### Program Includes:

\*The PC238USLC-11 comes standard with complimentary factory scheduled maintenance for the first 3 Years or 2,000 Hours, whichever comes first.

### Planned Maintenance Intervals at:

500/1000/1500/2000 hour intervals. (250 hr. initial interval for some products) Complimentary Maintenance Interval includes: Replacement of Oils & Fluid Filters with genuine Komatsu Parts, 50-Point inspection, Komatsu Oil & Wear Analysis Sampling (KOWA) / Travel & Mileage (distance set by distributor; additional charges may apply)

### Benefits of Using Komatsu CARE

- Assurance of Proper Maintenance with OEM Parts & Service
- Increased Uptime & Efficiency
- Factory Certified Technicians Performing Work
- Cost of Ownership Savings
- Transferable Upon Resale

### Complimentary KDPF Exchange

The PC238USLC-11 comes standard with 2 Complimentary KDPF Exchange Units for the first 5 Years. Complimentary KDPF Exchange Units are provided at: The suggested KDPF Exchange Units Service Intervals of 4,500 hours and 9,000 hours during the first 5 years. End User must have authorized Komatsu distributor perform the removal and installation of the KDPF.

### Complimentary SCR Maintenance

The PC238USLC-11 also includes 2 factory recommended services of the Selective Catalytic Reduction (SCR) Diesel Exhaust Fluid (DEF) system during the first 5 years or 9,000 hours whichever comes first. The service includes factory recommended DEF tank flush & strainer cleaning at the suggested service intervals of 4,500 hours & 9,000 hours.

## Komatsu CARE® – Extended Coverage

- Extended Coverage can provide peace of mind by protecting customers from unplanned expenses that effect cash flow
- Purchasing extended coverage locks-in the cost of covered parts and labor for the coverage period and helps turn these into fixed costs



## Komatsu Parts Support

- 24/7/365 to fulfill your parts needs
- 9 parts Distribution Centers strategically located across the U.S. and Canada
- Distributor network of more than 300 locations across U.S. and Canada to serve you
- Online part ordering through Komatsu eParts
- Remanufactured components with same-as-new warranties at a significant cost reduction



Interval PM	500	1000	1500	2000
KOWA SAMPLING (Engine, Hydraulics, Swing Circle, L & R Final Drives)	✓	✓	✓	✓
LUBRICATE MACHINE	✓	✓	✓	✓
LUBRICATE SWING CIRCLE	✓	✓	✓	✓
CHECK SWING PINION GREASE LEVEL AND ADD, WHEN NECESSARY	✓	✓	✓	✓
CHANGE ENGINE OIL	✓	✓	✓	✓
REPLACE ENGINE OIL FILTER	✓	✓	✓	✓
REPLACE FUEL PRE FILTER	✓	✓	✓	✓
REPLACE AC FRESH/RECIRC FILTERS	✓	✓	✓	✓
CLEAN AIR CLEANER ELEMENT	✓	✓	✓	✓
DRAIN SEDIMENT FROM FUEL TANK	✓	✓	✓	✓
COMPLETE 50 POINT INSPECTION FORM; LEAVE PINK COPY WITH CUSTOMER OR IN CAB	✓	✓	✓	✓
RESET MONITOR PANEL MAINTENANCE COUNTER FOR APPROPRIATE ITEMS	✓	✓	✓	✓
CHECK DAMPER CASE OIL LEVEL, ADD WHEN NECESSARY		✓		✓
REPLACE FUEL MAIN FILTER		✓		✓
REPLACE HYDRAULIC OIL FILTER ELEMENT		✓		✓
CHANGE SWING MACHINERY OIL		✓		✓
REPLACE HYDRAULIC TANK BREATHER ELEMENT		✓		✓
REPLACE DEF TANK BREATHER ELEMENT		✓		✓
CHANGE FINAL DRIVE OIL				✓
CLEAN HYDRAULIC TANK STRAINER				✓
REPLACE KCCV FILTER ELEMENT				✓
REPLACE DEF PUMP FILTER				✓
FACTORY TRAINED TECHNICIAN LABOR	✓	✓	✓	✓
2 KDPF Exchanges at 4,500 Hrs and 9,000 Hrs.				
2 SCR System Maintenance Services at 4,500 Hrs. and 9000 Hrs.				

## Komatsu Oil and Wear Analysis (KOWA)

- KOWA detects fuel dilution, coolant leaks, and measures wear metals
- Proactively maintain your equipment
- Maximize availability and performance
- Can identify potential problems before they lead to major repairs
- Reduce life cycle cost by extending component life

\* Certain exclusions and limitations apply. Refer to the customer certificate for complete program details and eligibility. Komatsu® and Komatsu Care® are registered trademarks of Komatsu Ltd. Copyright 2018 Komatsu America Corp.

PC238USLC-11

# KOMTRAX EQUIPMENT MONITORING

GET THE WHOLE STORY WITH  
**KOMTRAX**<sup>®</sup>

✓ **WHAT**

- KOMTRAX is Komatsu's remote equipment monitoring and management system
- KOMTRAX **continuously monitors and records** machine health and operational data
- Information such as fuel consumption, utilization, and a detailed history **lowering owning and operating cost**

✓ **WHEN**

- Knowing when machines are **running or idling** can help improve fleet utilization
- Detailed movement records ensure you know when and where your equipment is moved
- Up to date records allow you to **know when maintenance is due** and help you plan for future maintenance needs

✓ **WHERE**

- KOMTRAX data **can be accessed virtually anywhere** through your computer, the web or your smart phone
- Automatic alerts keep fleet managers up to date on the latest machine notifications

✓ **WHY**

- Knowledge is power - **make informed decisions** to manage your fleet better
- Knowing your idle time and fuel consumption will help maximize your machine efficiency
- **Take control of your equipment** - any time, anywhere

✓ **WHO**

- KOMTRAX is **standard** equipment on all Komatsu construction products



**KOMTRAX**<sup>®</sup>

For construction and compact equipment.

**KOMTRAX Plus**<sup>®</sup>

For production and mining class machines.

# SPECIFICATIONS



## ENGINE

Model..... Komatsu SAA6D107E-3\*  
 Type..... Water-cooled, 4-cycle, direct injection  
 Aspiration..... Variable Geometry Turbo air-to-air aftercooled  
 Number of cylinders..... 6  
 Bore..... 107 mm **4.21"**  
 Stroke..... 124 mm **4.88"**  
 Piston displacement..... 6.69 ltr **408 in<sup>3</sup>**  
 Horsepower:  
 SAE J1995..... Gross 123 kW **165 HP**  
 ISO 9249 / SAE J1349..... Net 123 kW **165 HP**  
 Fan at maximum speed..... Net 116 kW **156 HP**  
 Rated rpm..... 2000  
 Fan drive method for radiator cooling..... Mechanical with viscous fan clutch  
 Governor..... All-speed control, electronic  
 Lubrication system:  
 Method..... Gear pump, force-lubrication  
 Filter..... Full-flow  
 Air cleaner..... Air cleaner, double element and auto dust evacuator

\*EPA Tier 4 Final emissions certified



## HYDRAULICS

Type..... Closed-center system with load sensing valve and pressure compensated valve  
 Main pump:  
 Type..... Variable capacity piston type  
 Pumps for..... Boom, arm, bucket, swing, and travel circuits  
 Maximum flow..... 475 ltr/min **125.5 gal/min**  
 Hydraulic motors:  
 Travel..... 2 x piston motor with parking brake  
 Swing..... 1 x axial piston motor with swing holding brake  
 Relief valve setting:  
 Implement circuits..... 37.3 MPa 380 kgf/cm<sup>2</sup> **5,400 psi**  
 Travel circuit..... 37.3 MPa 380 kgf/cm<sup>2</sup> **5,400 psi**  
 Swing circuit..... 29.4 MPa 299 kgf/cm<sup>2</sup> **4,264 psi**  
 Pilot circuit..... 3.2 MPa 33 kgf/cm<sup>2</sup> **470 psi**  
 Hydraulic cylinders:  
 (Number of cylinders – bore x stroke x rod diameter)  
 Boom 2–130 mm x 1385 mm x 90 mm **5.11" x 54.5" x 3.5"**  
 Arm..... 1–135 mm x 1490 mm x 95 mm **5.3" x 58.7" x 3.7"**  
 Bucket.. 1–115 mm x 1120 mm x 80 mm **4.5" x 44.1" x 3.2"**



## DRIVES AND BRAKES

Steering control..... Two levers with pedals  
 Drive method..... Fully hydrostatic  
 Maximum drawbar pull..... 202 kN 20600 kgf **45,410 lbf**  
 Maximum travel speed: High..... 5.5 km/h **3.4 mph**  
 Medium..... 4.1 km/h **2.5 mph**  
 Low..... 3.0 km/h **1.9 mph**  
 Gradeability..... 70%, 35°  
 Service brake..... Hydraulic lock  
 Parking brake..... Mechanical disc



## SWING SYSTEM

Driven by..... Hydraulic motor  
 Swing reduction..... Planetary gear  
 Swing circle lubrication..... Grease-bathed  
 Swing lock..... Mechanical disc brake  
 Swing speed..... 11.0 rpm  
 Swing torque..... 6656 kg•m **48,124 ft lbs**



## UNDERCARRIAGE

Center frame..... X-frame leg  
 Track frame..... Box-section  
 Track type..... Sealed  
 Track adjuster..... Hydraulic  
 Number of shoes (each side)..... 49  
 Number of carrier rollers (each side)..... 2  
 Number of track rollers (each side)..... 9



## SOUND PERFORMANCE

Exterior – ISO 6395..... 100 dB(A)  
 Operator – ISO 6396..... 71 dB(A)



## COOLANT & LUBRICANT CAPACITY (REFILLING)

Fuel tank..... 290 ltr **76.6 U.S. gal**  
 Radiator..... 28.3 ltr **7.6 U.S. gal**  
 Engine..... 23.1 ltr **6.1 U.S. gal**  
 Final drive, each side..... 5.0 ltr **1.4 U.S. gal**  
 Swing drive..... 6.5 ltr **1.7 U.S. gal**  
 Hydraulic tank..... 126 ltr **33.3 U.S. gal**  
 DEF tank..... 13 ltr **3.4 U.S. gal**



## OPERATING WEIGHT (APPROXIMATE)

Operating weight including 5700 mm **18'8"** one-piece boom, 2925 mm **9'7"** arm, SAE heaped 0.85 m<sup>3</sup> **1.11 yd<sup>3</sup>** bucket, rated capacity of lubricants, coolant, full fuel tank, operator, and standard equipment.

Triple-Grouser Shoes	Operating Weight	Ground Pressure ISO 16754
Road Liner	24600 kg	51.1 kPa 0.52 kg/cm <sup>2</sup>
600 mm <b>24"</b>	<b>54,230 lb</b>	<b>7.41 psi</b>
700 mm	24870 kg	44.29 kPa 0.45 kg/cm <sup>2</sup>
<b>28"</b>	<b>54,825 lb</b>	<b>6.42 psi</b>
800 mm	25150 kg	39.19 kPa 0.39 kg/cm <sup>2</sup>
<b>31.5"</b>	<b>55,440 lb</b>	<b>5.68 psi</b>



## WORKING FORCES

### Component Weights

#### Arm including bucket cylinder and linkage

2925 mm **9'7"** arm assembly..... 1057 kg **2,331 lb**  
 2925 mm **9'7"** arm assembly w/piping..... 1080 kg **2,381 lb**

#### One piece boom including arm cylinder

5700 mm **18'8"** boom assembly..... 1788 kg **3,942 lb**  
 5700 mm **18'8"** boom assembly w/piping..... 1811 kg **3,992 lb**

Counterweight..... 6720 kg **14,815 lb**

Bucket 0.85 m<sup>3</sup> **1.11 yd<sup>3</sup>**..... 780 kg **1,719 lb**





## DIMENSIONS

	Arm Length	2925 mm	9'7"
	Boom length	5700 mm	18'8"
<b>A</b>	Overall length	8920 mm	29'3"
<b>B</b>	Overall height (to top of boom)*	2970 mm	9'9"
<b>C</b>	Length on ground (transport)	5030 mm	16'6"
<b>D</b>	Overall width with widest shoe	3180 mm	10'5"
<b>E</b>	Overall height (to top of cab)*	3065 mm	10'1"
<b>F</b>	Overall height (to top of handrail)*	3255 mm	10'8"
<b>G</b>	Ground clearance, counterweight	1075 mm	3'6"
<b>H</b>	Ground clearance, minimum	440 mm	1'5"
<b>I</b>	Tail swing radius	1810 mm	5'11"
<b>J</b>	Track length on ground	3655 mm	12'0"
<b>K</b>	Track length	4450 mm	14'7"
<b>L</b>	Track gauge	2380 mm	7'10"
<b>M</b>	Width of crawler (800 mm Shoe)	3180 mm	10'5"
	(700 mm Shoe)	3080 mm	10'2"
	(600 mm Shoe)	2980 mm	9'10"
<b>N</b>	Grouser height	26 mm	1"
<b>O</b>	Machine upper width	2980 mm	9'9"
<b>P</b>	Distance, swing center to rear end	1810 mm	5'11"

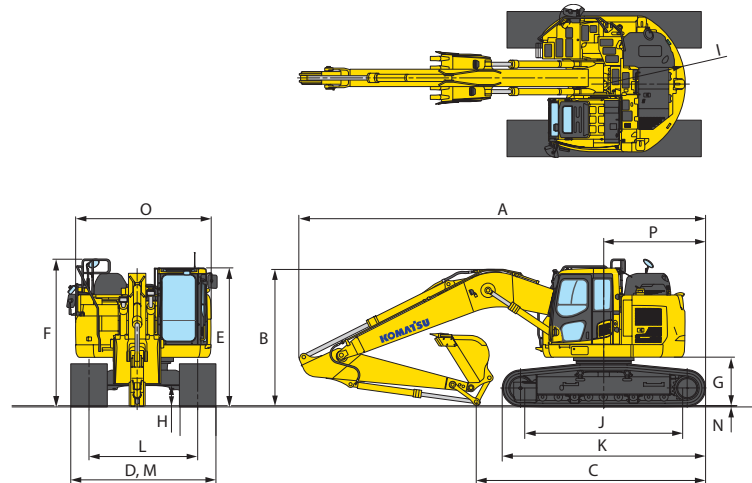

\* : Including grouser height



## BACKHOE BUCKET, ARM AND BOOM COMBINATION

Bucket Type	Bucket						Arm
	Capacity		Width		Weight		2.9 m (9'6")
Komatsu TL	0.50 m <sup>3</sup>	0.66 yd <sup>3</sup>	610 mm	24"	605 kg	1,334 lb	●
	0.67 m <sup>3</sup>	0.88 yd <sup>3</sup>	762 mm	30"	689 kg	1,518 lb	●
	0.85 m <sup>3</sup>	1.11 yd <sup>3</sup>	914 mm	36"	780 kg	1,719 lb	●
	1.02 m <sup>3</sup>	1.34 yd <sup>3</sup>	1067 mm	42"	857 kg	1,890 lb	○
	1.20 m <sup>3</sup>	1.57 yd <sup>3</sup>	1219 mm	48"	949 kg	2,092 lb	□
Komatsu HP	0.50 m <sup>3</sup>	0.66 yd <sup>3</sup>	610 mm	24"	652 kg	1,437 lb	●
	0.67 m <sup>3</sup>	0.88 yd <sup>3</sup>	762 mm	30"	763 kg	1,681 lb	●
	0.85 m <sup>3</sup>	1.11 yd <sup>3</sup>	914 mm	36"	868 kg	1,913 lb	●
	1.02 m <sup>3</sup>	1.34 yd <sup>3</sup>	1067 mm	42"	950 kg	2,095 lb	○
	1.20 m <sup>3</sup>	1.57 yd <sup>3</sup>	1219 mm	48"	1066 kg	2,349 lb	⊙
Komatsu HPS	0.50 m <sup>3</sup>	0.66 yd <sup>3</sup>	610 mm	24"	724 kg	1,597 lb	●
	0.67 m <sup>3</sup>	0.88 yd <sup>3</sup>	762 mm	30"	840 kg	1,851 lb	●
	0.85 m <sup>3</sup>	1.11 yd <sup>3</sup>	914 mm	36"	962 kg	2,120 lb	●
	1.02 m <sup>3</sup>	1.34 yd <sup>3</sup>	1067 mm	42"	1061 kg	2,339 lb	□
	1.20 m <sup>3</sup>	1.57 yd <sup>3</sup>	1219 mm	48"	1193 kg	2,630 lb	⊙
Komatsu HPX	0.50 m <sup>3</sup>	0.66 yd <sup>3</sup>	610 mm	24"	824 kg	1,817 lb	●
	0.67 m <sup>3</sup>	0.88 yd <sup>3</sup>	762 mm	30"	939 kg	2,071 lb	●
	0.85 m <sup>3</sup>	1.11 yd <sup>3</sup>	914 mm	36"	1061 kg	2,340 lb	○
	1.02 m <sup>3</sup>	1.34 yd <sup>3</sup>	1067 mm	42"	1161 kg	2,559 lb	□
	1.20 m <sup>3</sup>	1.57 yd <sup>3</sup>	1219 mm	48"	1293 kg	2,850 lb	⊙

● - Used with material weights up to 3,500 lb/yd<sup>3</sup>  
Quarry/rock/high abrasion applications

○ - Used with material weights up to 3,000 lb/yd<sup>3</sup>  
Tough digging applications

□ - Used with material weights up to 2,500 lb/yd<sup>3</sup>  
General construction

⊙ - Used with material weights up to 2,000 lb/yd<sup>3</sup>  
Light materials applications

# SPECIFICATIONS



## WORKING RANGE

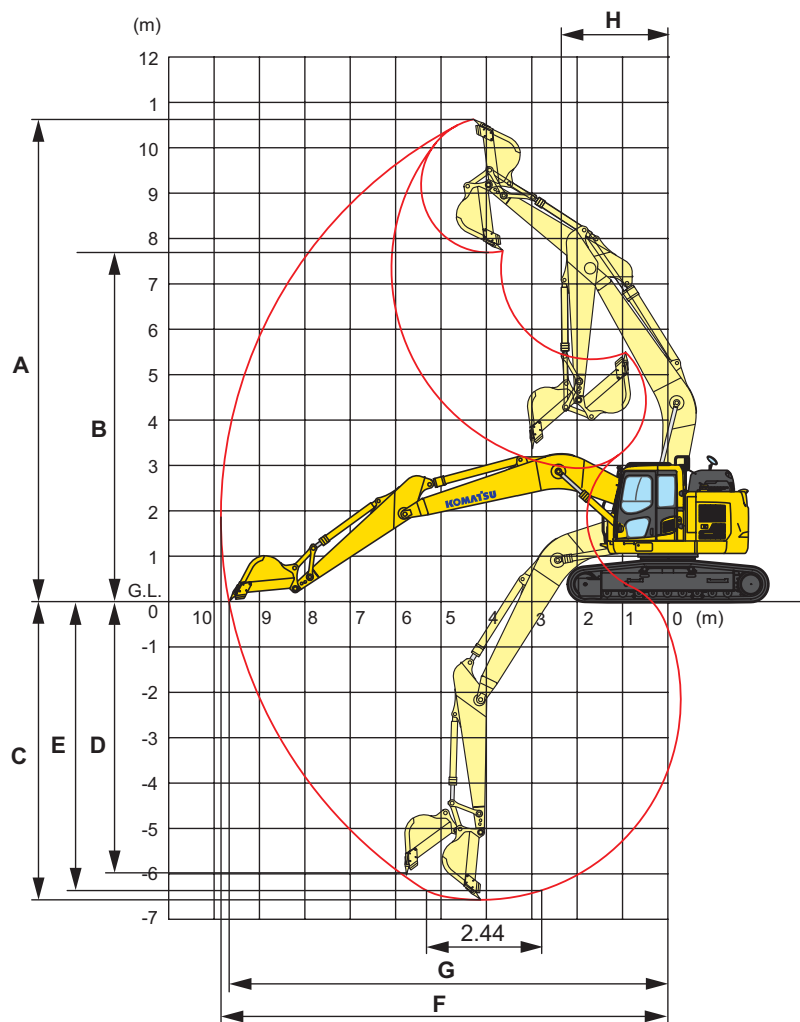

	Arm Length	2925 mm	9'7"
<b>A</b>	Max. digging height	10700 mm	35'1"
<b>B</b>	Max. dumping height	7825 mm	25'8"
<b>C</b>	Max. digging depth	6620 mm	21'9"
<b>D</b>	Max. vertical wall digging depth	5980 mm	19'7"
<b>E</b>	Max. digging depth for 8' level bottom	6370 mm	20'11"
<b>F</b>	Max. digging reach	9875 mm	32'5"
<b>G</b>	Max. digging reach at ground level	9700 mm	31'10"
<b>H</b>	Min. swing radius	2310 mm	7'7"
<b>ISO rating</b>	Bucket digging force at power max	149 kN 15200 kgf / 33,500 lb	
	Arm crowd force at power max	108 kN 11000 kgf / 24,250 lb	
<b>SAE rating</b>	Bucket digging force at power max	132 kN 13500 kgf / 29,760 lb	
	Arm crowd force at power max	103 kN 10500 kgf / 23,150 lb	

# LIFT CAPACITIES



## LIFTING CAPACITY WITH LIFTING MODE

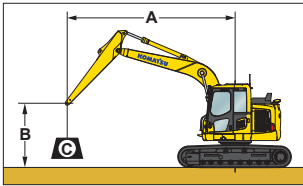

- A: Reach from swing center
- B: Bucket hook height
- C: Lifting capacity
- Cf: Rating over front
- Cs: Rating over side
- ☉: Rating at maximum reach

- Conditions:
- 5700 mm 18'8" one-piece boom
  - Counterweight (total mass): 6720 kg 14,815 lb
  - Bucket: None
  - Lifting mode: On

Arm: 2925 mm 9'7" Shoes: 600 mm 24" Road Liners

Unit: kg lb

B	A		1.5 m 5'		3.0 m 10'		4.6 m 15'		6.1 m 20'		7.6 m 25'		☉ MAX			
	Cf	Cs	Cf	Cs	Cf	Cs	Cf	Cs	Cf	Cs	Cf	Cs	☉	Cf	Cs	
6.1 m																
20'																
4.6 m																
15'																
3.0 m																
10'																
1.5 m																
5'																
0 m																
0'																
-1.5 m																
-5'																
-3.0 m																
-10'																
-4.6 m																
-15'																

Arm: 2925 mm 9'7" Shoes: 700 mm 28" triple grouser

Unit: kg lb

B	A		1.5 m 5'		3.0 m 10'		4.6 m 15'		6.1 m 20'		7.6 m 25'		☉ MAX			
	Cf	Cs	Cf	Cs	Cf	Cs	Cf	Cs	Cf	Cs	Cf	Cs	☉	Cf	Cs	
6.1 m																
20'																
4.6 m																
15'																
3.0 m																
10'																
1.5 m																
5'																
0 m																
0'																
-1.5 m																
-5'																
-3.0 m																
-10'																
-4.6 m																
-15'																

Arm: 2925 mm 9'7" Shoes: 800 mm 31.5" triple grouser

Unit: kg lb

B	A		1.5 m 5'		3.0 m 10'		4.6 m 15'		6.1 m 20'		7.6 m 25'		☉ MAX			
	Cf	Cs	Cf	Cs	Cf	Cs	Cf	Cs	Cf	Cs	Cf	Cs	☉	Cf	Cs	
6.1 m																
20'																
4.6 m																
15'																
3.0 m																
10'																
1.5 m																
5'																
0 m																
0'																
-1.5 m																
-5'																
-3.0 m																
-10'																
-4.6 m																
-15'																

\*Load is limited by hydraulic capacity rather than tipping. Ratings are based on ISO standard No. 10567. Rated loads do not exceed 87% of hydraulic lift capacity or 75% of tipping load.



## STANDARD EQUIPMENT

### ENGINE

- Automatic engine warm-up system
- Dry type air cleaner, double element
- Engine, Komatsu SAA6D107E-3
- Engine overheat prevention system
- Fuel pre-filter (With water separator)

### ELECTRICAL SYSTEM

- Alternator, 21 V/85 A
- Auto-decelerator
- Batteries, large capacity
- Converter, 12 V
- Electric horn
- Starting motor, 24 V/5.5 kW
- Working light, 3 (Boom and cab)

### HYDRAULIC SYSTEM

- Arm holding valve
- Boom holding valve
- Pattern change valve (ISO to BH)
- Pressure Proportional Control (PPC) hydraulic control system
- Power maximizing system
- Service valve (1 additional)
- Three Speed travel with auto shift
- Working mode selection system

### GUARDS AND COVERS

- Fan guard structure
- Pump/engine partition cover
- Revolving frame undercovers
- Track frame undercover
- Track roller guard, center section

### UNDERCARRIAGE

- Hydraulic track adjusters (Each side)
- Track rollers, 9 each side
- Track shoe, 700 mm **28"** triple grouser

### OPERATOR ENVIRONMENT

- A/C with defroster
- AM/FM radio
- Auxiliary input (3.5 mm jack)
- High back suspension seat wth heat
- Large high resolution LCD monitor
- Lock lever
- Mirrors (RH, LH, sidewise)
- Operator protective top guard, OPG level 1 (ISO 10262)
- Rear view monitor system
- ROPS cab (ISO 12117-2)
- Seat belt, retractable
- Skylight

### OTHER EQUIPMENT

- Battery disconnect switch
- Cooling fan, suction type with viscous clutch
- Counterweight, 6720 kg **14,815 lb**
- Engine shutdown secondary switch
- Equipment Management Monitoring System
- KOMTRAX
- Radiator and oil cooler dust proof net
- Rear reflector
- Slip-resistant plates
- Travel alarm



## OPTIONAL EQUIPMENT

### HYDRAULIC SYSTEM

- Hydraulic control unit
  - One additional actuator
- Proportional control handles

### GUARDS AND COVERS

- Cab guards
  - Full front guard, OPG level 1 (ISO 10262)
  - Full front guard, OPG level 2 (ISO 10262)
  - Bolt-on top guard, OPG level 2 (ISO 10262)
  - Lower front window guard

### UNDERCARRIAGE

- Shoes
  - 800 mm **31.5"** triple grouser
  - 600 mm **24"** road liner

### OPERATOR ENVIRONMENT

- Cab accessories
  - Rain visor
  - Sun visor

### OTHER EQUIPMENT

- KomVision
- Right side view monitor system
- Working light, two on cab

### WORK EQUIPMENT

- Arms
  - 2925 mm **9'7"** arm assembly
  - 2925 mm **9'7"** arm assembly with piping
- Booms
  - 5700 mm **18'8"** HD boom assembly
  - 5700 mm **18'8"** HD boom assembly with piping



## ATTACHMENT OPTION

- JRB attachments
  - Couplers
  - Smart-Loc
  - Versa-Loc

- Komatsu buckets
- PSM thumbs
- Rockland thumbs

For a complete list of available attachments, please contact your local Komatsu distributor.

# KOMATSU®

*Note: All comparisons and claims of improved performance made herein are made with respect to the prior Komatsu model unless otherwise specifically stated.*